

User manual

PLP Lobe pumps



Pomac Pumps

Pomac bv - Feithspark 13 - 9356 BX Tolbert - the Netherlands
Tel +31(0) 594 512877 - Fax +31(0) 594 517002
info@pomacpumps.com - www.pomacpumps.com

This user manual has been released d.d.:.....
 and belongs to:

| | | | | | | | | | | | | | | | | | |
|------------|--|--|--|--|--|--|--|--|--|--|--|--|--|--|--|--|--|
| PLP | | | | | | | | | | | | | | | | | |
|------------|--|--|--|--|--|--|--|--|--|--|--|--|--|--|--|--|--|

| | | |
|---------------------------|----|-------------------|
| Pump serial number | | |
| | | |
| capacity | | m ³ /h |
| pressure | | bar |
| NPSHR | | m |
| | | |
| Drive, make | | |
| type | | |
| speed | | min ⁻¹ |
| voltage Δ / ▲ | / | V |
| frequency | | Hz |
| current | | A |
| power | | kW |
| isolation class | | |
| protection class | IP | |
| area classification | | |
| | | |
| Coupling, make | | |
| type | | |
| size | | |

User manual Pomac PLP Lobe pump

This manual has been compiled with the utmost care.
However, POMAC assumes no liability for possible deficiencies of the information in this manual. It is the responsibility of the buyer/user of this pump to ensure this information is complete and up-to-date.

All technical information mentioned in this user manual remains property of Pomac bv and may only be used for the installation, operation and maintenance of this pump. The information may not be copied, duplicated or passed on to third parties without our written permission.

Copyright 2010 Pomac bv

Release date: June 2014

Doc. ID. : **CE/PLP (1406) EN-12**

DECLARATION OF INCORPORATION

(according to Annex II 1 B of the Machinery Directive (2006/42/EC – 1st Edition – December 2009)

Pomac bv
Feithspark 13
9356 BX Tolbert
The Netherlands

hereby declares completely under own responsibility that the pump mentioned below:

Model: Lobe pump
Type: **PLP**
Execution: bare shaft
Materials: 1.4404

to which this declaration refers to, is in conformity with the following standards:

Standards: EN-ISO 12100 parts 1 & 2
NEN-EN 60204 part 1
EN 809

The pump must not be put into service until the final machinery into which it is to be incorporated has been declared in conformity with the provisions of this Directive (2006/42/EC), where appropriate.

Issued at Tolbert, 29th of December 2009

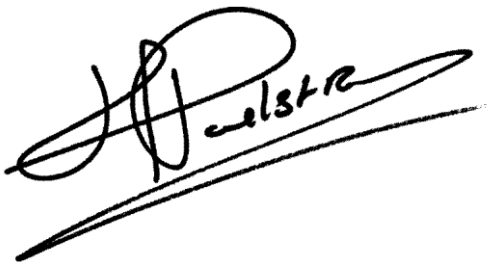
A handwritten signature in black ink, appearing to read 'H. Poelstra', is written over a horizontal line. The signature is stylized and cursive.

H. Poelstra
Managing Director

Table of contents

| | | |
|--------|---|----|
| 1. | Introduction..... | 5 |
| 1.1. | General information..... | 5 |
| 1.2. | Warranty..... | 5 |
| 1.3. | Transport and receipt..... | 5 |
| 1.4. | Manufacturer..... | 5 |
| 2. | Safety..... | 6 |
| 2.1. | General information..... | 6 |
| 2.2. | Instructions..... | 6 |
| 2.3. | Staff..... | 6 |
| 2.4. | Changed application..... | 6 |
| 3. | General information..... | 7 |
| 3.1. | Pump identification..... | 7 |
| 3.2. | Operating principle..... | 10 |
| 3.3. | Delivery program..... | 10 |
| 3.4. | Application area..... | 10 |
| 3.5. | Construction..... | 11 |
| 3.6. | Safety valve (optional)..... | 12 |
| 3.6.1. | Safety valve types..... | 12 |
| 3.6.2. | Description of the safety valve..... | 12 |
| 3.6.3. | Connections of the air-loaded safety valve..... | 12 |
| 4. | Installation..... | 13 |
| 4.1. | General information..... | 13 |
| 4.2. | Transport..... | 13 |
| 4.3. | Hoisting..... | 13 |
| 4.4. | Safety..... | 14 |
| 4.5. | Foundation..... | 14 |
| 4.6. | Built-in dimensions..... | 14 |
| 4.7. | Piping..... | 15 |
| 4.8. | Pump with safety valve..... | 16 |
| 4.9. | Pump-unit assembly..... | 16 |
| 4.10. | Coupling alignment..... | 16 |
| 4.11. | Alignment tolerances..... | 17 |
| 4.12. | Fitting additional connections..... | 17 |
| 4.13. | Flushing the system..... | 19 |
| 4.14. | Establishing the direction of rotation..... | 21 |
| 4.15. | Connecting the drive..... | 21 |
| 4.16. | Oil filling..... | 21 |
| 5. | Operation..... | 22 |
| 5.1. | Checking..... | 22 |
| 5.2. | Start Up..... | 22 |
| 5.3. | Adjusting the safety valve..... | 22 |
| 5.3.1. | Adjusting a spring loaded safety valve..... | 22 |
| 5.3.2. | Adjusting an air loaded safety valve..... | 23 |
| 5.4. | In operation..... | 24 |
| 5.5. | Operating principle of the safety valve..... | 24 |
| 5.6. | Shutting down..... | 24 |
| 6. | Maintenance..... | 25 |
| 6.1. | General survey..... | 25 |
| 6.2. | Oil change..... | 25 |
| 7. | Disassembly / assembly..... | 26 |
| 7.1. | Ordering spare parts..... | 26 |
| 7.2. | Safety measures..... | 26 |
| 7.3. | Special tools..... | 26 |
| 7.4. | Draining the pump..... | 27 |
| 7.5. | Oil draining..... | 27 |
| 7.6. | Dismantling the pump..... | 27 |
| 7.7. | Pump disassembly..... | 27 |
| 7.8. | Disassembly of a safety valve..... | 29 |

| | | |
|---------|--|----|
| 7.8.1. | Disassembly of a spring loaded safety valve..... | 29 |
| 7.8.2. | Disassembly of an air loaded safety valve | 30 |
| 7.9. | Parts inspection..... | 30 |
| 7.10. | Gearbox assembly | 31 |
| 7.11. | Adjusting the axial rotor clearance..... | 33 |
| 7.12. | Shaft seal assembly | 35 |
| 7.12.1. | Single mechanical seal assembly, types M1, M3 and M4 | 35 |
| 7.12.2. | Double mechanical seal assembly, types M2 and M5 | 35 |
| 7.12.3. | O-ring seal assembly, types O1, O2, O3 and O4 | 35 |
| 7.12.4. | Lip seal assembly, type L | 36 |
| 7.13. | Rotor assembly | 36 |
| 7.14. | Adjusting the timing of 'quattro lobes' | 36 |
| 7.15. | Front cover assembly..... | 37 |
| 7.16. | Gearbox assembly | 37 |
| 7.17. | Assembly of a safety valve | 38 |
| 7.17.1. | Assembly of a spring-loaded safety valve..... | 38 |
| 7.17.2. | Assembly of an air-loaded safety valve | 38 |
| 7.18. | Filling with oil..... | 38 |
| 8. | Closing down..... | 39 |
| 8.1. | Dismantling | 39 |
| 8.2. | Storage..... | 39 |
| 8.3. | Disposal | 39 |
| 9. | Technical data | 40 |
| 9.1. | Oil types | 40 |
| 9.2. | Oil quantities | 40 |
| 9.3. | Dimensions | 41 |
| 9.4. | Sectional drawing..... | 42 |
| 9.5. | Parts lists..... | 43 |
| 9.5.1. | Part list with article numbers PLP 1 | 43 |
| 9.5.2. | Part list with article numbers PLP 15 | 44 |
| 9.5.3. | Part list with article numbers PLP 2 | 45 |
| 9.5.4. | Part list with article numbers PLP 3 | 46 |
| 9.5.5. | Part list with article numbers PLP 4 | 47 |
| 9.6. | Materials specification..... | 48 |
| 9.7. | Shaft seals | 49 |
| 9.7.1. | Single mechanical seal , type M1 | 49 |
| 9.7.2. | Single mechanical seal , type M4 | 50 |
| 9.7.3. | Double mechanical seal, type M2..... | 51 |
| 9.7.4. | Double mechanical seal, type M5..... | 52 |
| 9.7.5. | Single O-ring seal, type O1..... | 53 |
| 9.7.6. | Single O-ring seal, type O3..... | 54 |
| 9.7.7. | Double O-ring seal, type O2 | 55 |
| 9.7.8. | Double O-ring seal, type O4 | 56 |
| 9.7.9. | Lip seal, type L1 | 57 |
| 9.7.10. | Lip seal, type L2 | 58 |
| 9.7.11. | Lip seal, type L3 | 59 |
| 9.8. | Spring loaded safety valve | 60 |
| 9.9. | Air loaded safety valve | 61 |
| 10. | Trouble shooting..... | 62 |

1. Introduction

1.1. General information

This manual provides important information regarding the correct way of installing, operating and servicing this pump.

This manual also provides information necessary to prevent the installer/operator from injury or discomfort during installation and operation of this pump and to ensure the correct use and reliable performance of this pump.

This manual represents the most recent information regarding the pump types mentioned in this manual at the time of going to print. However, POMAC reserves the right to modify the construction of the pump types mentioned, as well as the contents of this manual, without prior or afterward notification.

Read this manual thoroughly before installing, operating or servicing this pump. Ensure that operators and maintenance staff are familiar with the symbols used. Follow the instructions in this manual step by step.

1.2. Warranty

Warranty is strictly limited to the conditions specified by POMAC and will only be granted according to these conditions.

Warranty will only come into force provided that:

- the pump has been installed and put into operation strictly in accordance with the instructions given in this manual.
- maintenance and repairs have been carried out according to the instructions given in this manual.
- exclusively original POMAC parts or parts provided by POMAC have been used for replacing parts.
- the pump has not been used for applications other than those shown in the specifications according to which the pump was sold.
- no changes have been made to the construction of the pump itself by the buyer.
- the damage is not the result of work carried out by persons not qualified or appointed.
- the damage has not been caused through major force.

1.3. Transport and receipt

- Check to see if the pump has not been subject to damage during transportation. If this is the case, report it directly to the carrier and to POMAC;
- If the pump is delivered on a pallet, leave it on the pallet for as long as possible. This facilitates internal transport.

1.4. Manufacturer

PLP lobe pumps are manufactured by

Pomac bv
Feithspark 13
9356 BX Tolbert
The Netherlands
Tel +31(0) 594 512877
Fax +31(0) 594 517002
info@ pomacpumps.com
www.pomacpumps.com

2. Safety

2.1. General information

This manual provides information necessary to prevent the installer/operator from injury or discomfort during installation and operation of this pump and to ensure the correct use and reliable performance of this pump.

- Read this manual thoroughly before installing, operating or servicing this pump.
- Ensure that operators and maintenance staff are familiar with the contents of this manual and with the instructions given.
- Ensure that operators and maintenance staff are familiar with the symbols used.
- Follow the instructions in this manual step by step.
- Store this manual in a place that is known and accessible to any user.

2.2. Instructions

This manual contains instructions with regard to the safety of the user, the continued good functioning of the pump and hints to facilitate certain actions or procedures. These instructions are indicated with the following symbols:



Warning! Can cause injury to the user! Act strictly in accordance with the instructions given!



Caution! Can cause severe damage to the pump or bad functioning! Closely follow the instructions given!



Note: Hint or instruction that can facilitate certain actions.

- Issues which require extra attention are printed in **bold**.

2.3. Staff

All personnel, in charge of the installation, operation or maintenance and overhaul of the pump, should have received the necessary training.

2.4. Changed application

- Contact POMAC in case the pump is going to be used for other applications or in different circumstances than those specified during the initial pump selection.

3. General information

3.1. Pump identification

Each pump has a unique serial number and a type number. Both are stated on the type plate of the pump.

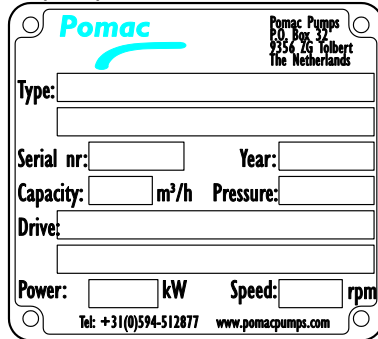

The type number describes the set-up of the pump and is composed as follows:

| PLP *) | x | x | x.. | x | x | x | x | x | x.. | x | x | x | x | x | x | x |
|--------|---|---|-----|---|---|---|---|---|-----|----|----|----|----|----|----|----|
| | 1 | 2 | 3 | 4 | 5 | 6 | 7 | 8 | 9 | 10 | 11 | 12 | 13 | 14 | 15 | 16 |

*) PLPH in case of hydraulic drive,
PLPS in case of split pump casing.

Example: **PLP 2-2 01 01 M1 V V P2 S1 C1 01 G1 H1 V1 R1 W1**

1. Gearbox size

- 1 = gearbox size 1
- 15 = gearbox size 1,5
- 2 = gearbox size 2
- 3 = gearbox size 3
- 4 = gearbox size 4

2. Connection diameter

- $\frac{3}{4}$ = $\frac{3}{4}$ "
- 1 = 1"
- 1,5 = 1,5"
- 2 = 2"
- 2,5 = 2,5"
- 3 = 3"
- 4 = 4"

3. Connection type suction side

- 01.. = hygienic thread acc. to DIN 11851
- 02.. = SMS 1145
- 03.. = Tri-clamp ISO 2852
- 04.. = DIN 11864-1
- 05.. = DIN 11864-2
- 06.. = flanges acc. to EN1092-1
- 07.. = BSP-thread
- 08.. = NPT-thread
- 09.. = rectangular port
- 10.. = Tri-clamp DIN 32676
- xx.. = acc. to client specification

The codes at pos .. determine the position of the suction connection.

For horizontal pump position:

R = suction position at right hand side, seen from shaft end.

L = suction position at left hand side, seen from shaft end.

For vertical pump position:

T = suction position = top

B = suction position = bottom

4. Connection type discharge side

- 01 = hygienic thread acc. to DIN 11851
- 02 = SMS 1145
- 03 = Tri-clamp ISO 2852
- 04 = DIN 11864-1
- 05 = DIN 11864-2
- 06 = flanges acc. to EN1092-1
- 07 = BSP-thread
- 08 = NPT-thread
- 09 = rectangular port
- 10 = Tri-clamp DIN 32676
- xx = acc. to client specification

5. Type shaft seal

- M1 = single mechanical seal SiC/SiC
- M2 = double mechanical seal quench or flush SiC/SiC - SiC/SiC
- M3 = single mechanical seal with small seal faces SiC/SiC
- M4 = single mechanical seal TC/TC
- M4V = retracted single mechanical seal TC/TC
- M5 = double mechanical seal quench or flush TC/TC - TC/TC
- M6 = dubbel mechanical seal met quench of flush TC/TC - SiC/SiC
- M7 = dubbel mechanical seal met quench of flush SiC/SiC - TC/TC

- O1 = single O-ring, hardened stainless steel shaft sleeve
- O2 = double O-ring with quench, hardened stainless steel shaft sleeve
- O3 = single O-ring, ceramic shaft sleeve
- O4 = double O-ring with quench, ceramic shaft sleeve
- L1 = PTFE lip seal, hardened stainless steel shaft sleeve
- L2 = PTFE lip seal, ceramic shaft sleeve
- L3 = WDR PTFE lip seal, ceramic hardened stainless steel shaft sleeve

6. Elastomers shaft seal

- V = Viton
- E = EPDM
- N = NBR
- S = Silicon
- T = Teflon
- K = Kalrez
- VC = VITON with general statement of conformity to FDA
- EC = EPDM with general statement of conformity to FDA
- X = acc. to client specification

7. Elastomers static O-rings

- V = Viton
- E = EPDM
- N = NBR
- S = Silicon
- T = Teflon
- K = Kalrez
- VC = VITON with general statement of conformity to FDA
- EC = EPDM with general statement of conformity to FDA
- X = acc. to client specification

8. Position connections and shaft

- P0 = connections horizontal, shaft top = standard,
- P1 = connections horizontal, shaft bottom
- P2 = connections vertical, shaft right hand from shaft end
- P3 = connections vertical, shaft left hand from shaft end

9. Self draining execution

- S1 = 45°
- S2 = plane
- S3 = 2x 45°

10. Additional radial / axial clearance between lobe and pump casing,

C = Radial clearance at the lobe circumference and axial clearance at the rear and front side

- C1 = + 0,05
- C2 = + 0,1
- C3 = + 0,15
- C4 = +0,2
- C-1 = - 0,05

11. Internal surface treatment

- O1 = mechanical polish to 0,8 micron
- O2 = electro polish to 0,5 micron
- O3 = electro polish to 0,8 micron
- O4 = mechanical polish to 0,5 micron

12. Hardened pump parts

- G1 = pump casing, lobes, cover, Hard inchromizing
- G2 = pump casing, cover, Hard inchromizing
- G3 = lobes , Hard inchromizing
- G4 = pump casing, lobes, cover, Plasma nitriding
- G5 = pump casing, cover, Plasma nitriding
- G6 = lobes , Plasma nitriding

13. Heating jacket

- H1 = heating jacket on front cover
- H2 = heating jacket on rotor case
- H3 = H1 + H2
- H4 = Electrical pump cover heating

14. Safety relief valve

- V1 = safety relief valve, spring loaded
- V2 = safety relief valve, pneumatically controlled

15. Lobes / timing mechanism

- R1 = biwing lobe with timing mechanism
- R2 = quattro lobe with timing mechanism

16. Material options.

- W1 = pump casing, lobes, pump cover: 1.4435
- W2 = lobes non-galling
- W3 = pump casing, lobes, pump cover: Hastelloy CX2MW N26022
- W4 = pump casing, lobes, pump cover: 1.4571, 316 TI

3.2. Operating principle

A lobe pump is a rotary positive displacement pump. The operating principle is based on the counter-rotation of 2 rotors in a chamber. Both rotors are mounted on shafts. The shafts are supported by bearing cartridges, which are directly mounted to the pump casing. One of the shafts is externally driven. An internal gear transmission drives the other shaft in opposite direction. The rotors run synchronously in the opposite directions, without touching each other. When the rotors pass the suction port the volume between the rotors increases. This creates a pressure decrease which causes the liquid to flow into the suction port. During rotation a fixed amount of liquid is conveyed.

When the rotors approach the pressure port the volume between the rotors decreases. This creates a pressure increase which causes the liquid to flow out of the pressure port.

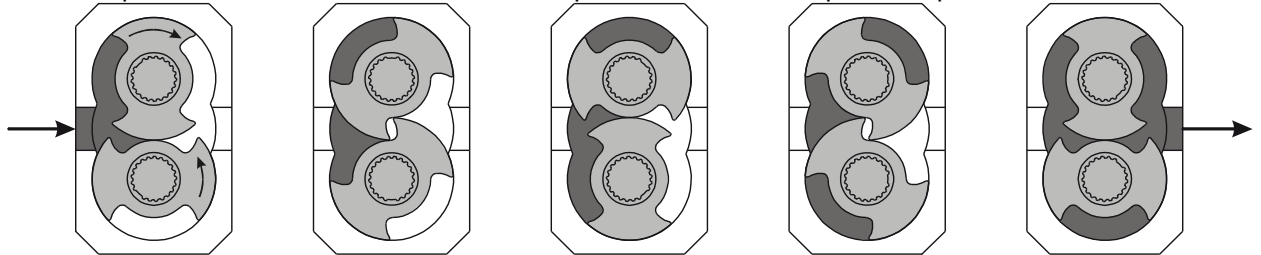

3.3. Delivery program

Connections

The delivery program comprises pump types with connections of ¾", 1", 1 ½", 2", 2 ½", 3" and 4".

The pump can be placed with its connections either horizontally or vertically.

Shaft seals

The following shaft seal variants are available:

- Single mechanical seal
- Double mechanical seal, quenched or flushed
- O-ring seal
- Double O-ring seal, quenched
- Lip seal.

3.4. Application area

| Type | displacement [lit/100 rev.] | max. pressure [bar] | max. speed [rev./min] | weight [kg] |
|-----------|-----------------------------|---------------------|-----------------------|-------------|
| PLP 1- ¾ | 4 | 15 | 1500 | 12 |
| PLP 1-1 | 6 | 15 | 1500 | 12,5 |
| PLP 1-1,5 | 10 | 15* | 1200 | 13 |
| PLP 15-2 | 20 | 8 | 1200 | 23,2 |
| PLP 2-1,5 | 22 | 15 | 1200 | 37 |
| PLP 2-2 | 30 | 15 | 1200 | 39 |
| PLP 2-2,5 | 36 | 15* | 1000 | 44 |
| PLP 3-2 | 55 | 15 | 1000 | 101 |
| PLP 3-3 | 100 | 15 | 1000 | 105 |
| PLP 3-4 | 130 | 15* | 750 | 115 |
| PLP 4-4 | 250 | 15 | 750 | 295 |

*) Dependent on the gap between rotor and pump casing.

The values mentioned above are maximum values. The operational values may be lower because of the liquid characteristics or the system design.

3.5. Construction

The pump comprises of the following parts:

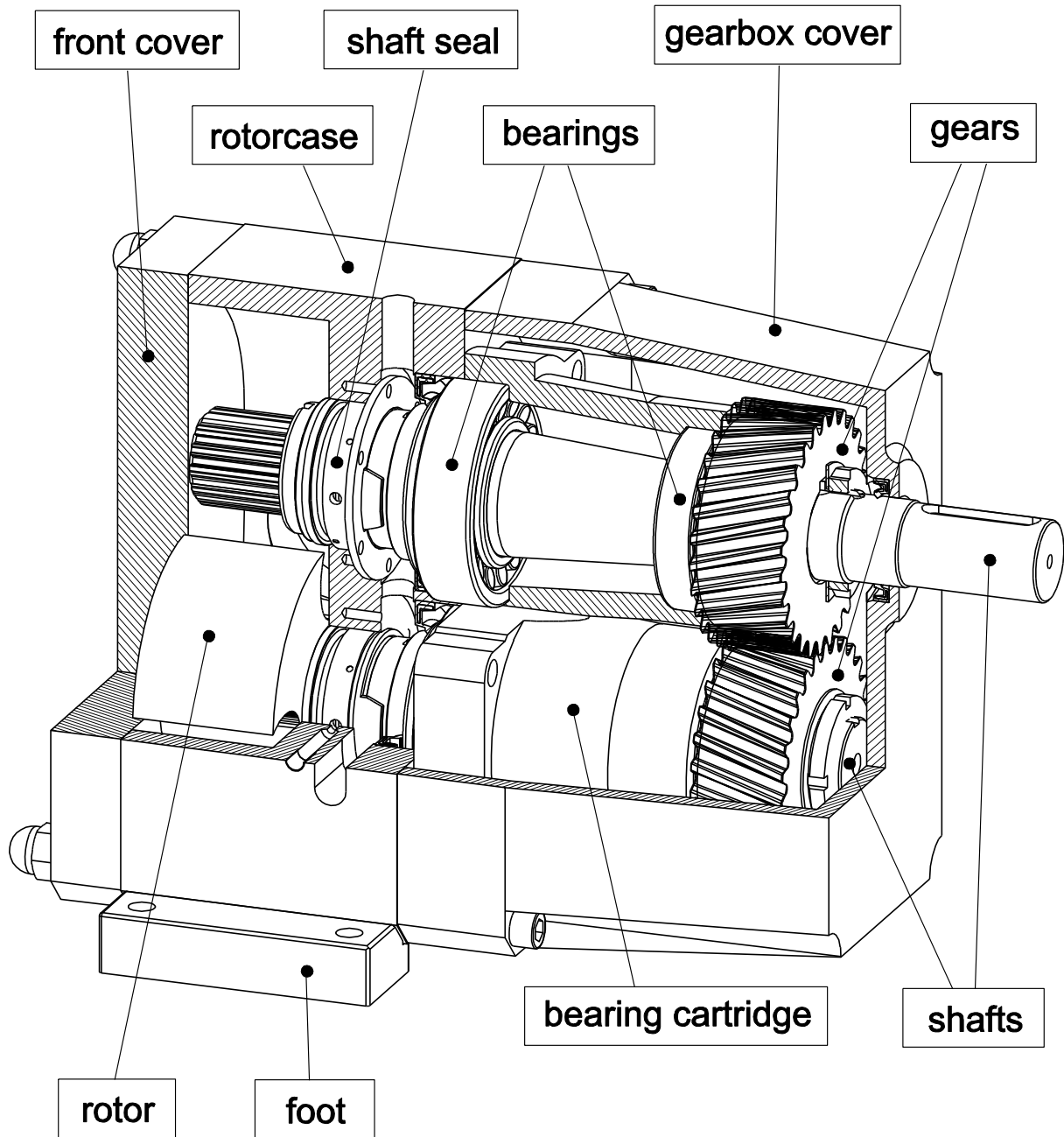

3.6. Safety valve (optional)

3.6.1. Safety valve types

The PLP can be supplied with a spring-loaded or air-operated safety valve. The opening pressure is adjustable by means of a setscrew.

The following types can be provided with a safety valve:

| | PLP 1-3/4 PLP 1-1 PLP 1-1.5 | PLP 15-2 | PLP 2-1.5 PLP 2-2 PLP 2-2,5 | PLP 3-2 PLP 3-3 PLP 3-4 | PLP 4-4 |
|----------------------------|-----------------------------------|----------|-----------------------------------|-------------------------------|---------|
| spring loaded safety valve | V | V | V | V | |
| air-operated safety valve | | | | | V |

3.6.2. Description of the safety valve

The Pomac safety valve is mounted directly to the pump cover. This facilitates maintenance and guarantees optimal hygienic conditions. When the valve opens a direct by-pass is created between pressure side and suction side of the pump.

The valve covers almost completely the front side of the rotors and the spaces on suction side and pressure side partially. At pump side the valve is submitted to the differential pressure inside the pump; the air pressure or spring load exerts the external force on the valve. Because fluid characteristics, pressure division, process factors, etc. all can influence the load characteristic on the valve, the load must be adjusted on-site.

When the differential pressure inside the pump exceeds the closing pressure, exerted by the load set, the valve will open. Dimensions of valve and valve housing are such, that a part of the pump capacity can be by-passed from pressure side to suction side.

3.6.3. Connections of the air-loaded safety valve

Connection A : Air pressure

Connection B : Valve vent (always has to be open)

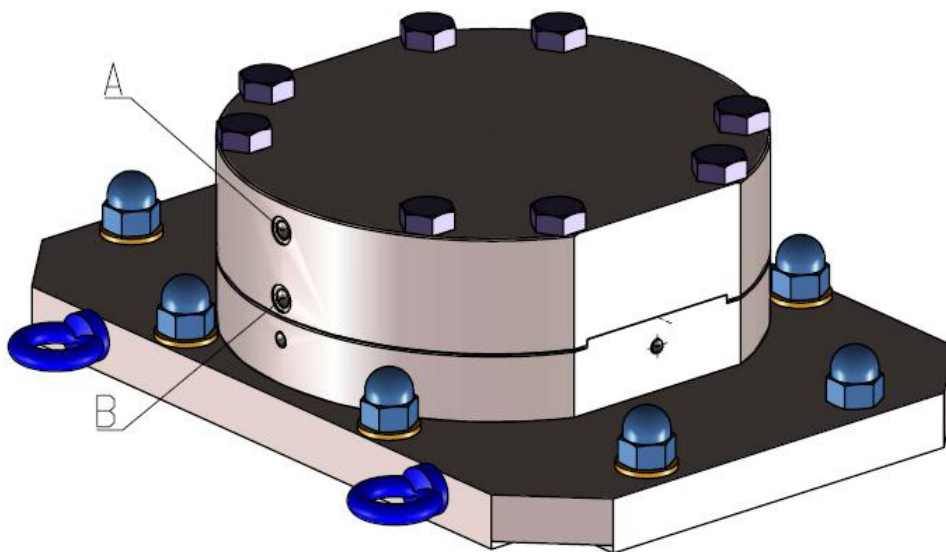

4. Installation

4.1. General information

- The foundation must be solid, flat and level.
- The area, in which the pump is placed, must be well vented. Too high a temperature or air humidity, or a dusty atmosphere, may have negative effects on the performance of an electric motor.
- The area around the pump-unit must be sufficient for the pump to be operated, cleaned or repaired.
- To ensure an unobstructed air supply to an electric motor there must be a free space behind the fan cover, equal to 1/4 of its diameter.



All work on and with the pump must always be in accordance with all the prevailing standards regarding occupational health and safety as well as machine safety.

4.2. Transport

- In case the pump or the pump-unit is delivered on a pallet, leave it on the pallet as long as possible. This will facilitate the internal transport.

4.3. Hoisting

- If there is a proper hoisting device available, use this to move the pump(-unit).



Never stand underneath a hoisted pump!

- In case the pump is assembled with a motor on a baseplate, the pump-unit must always be hoisted with the straps fixed as shown in the following figure:

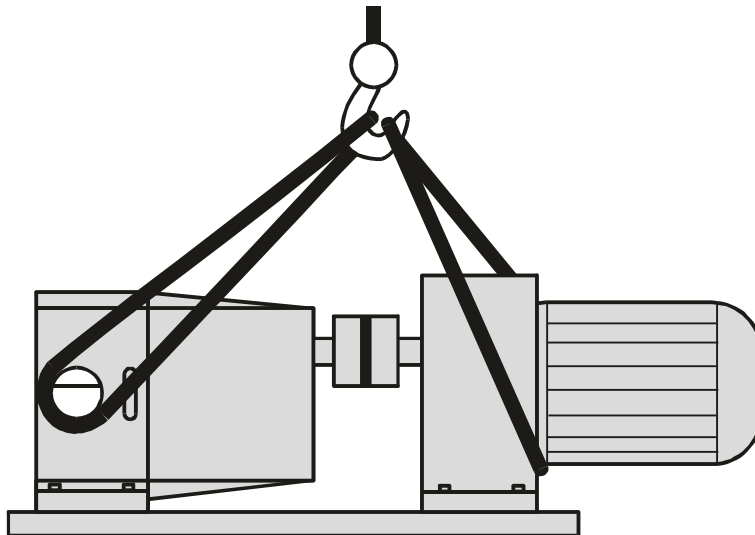

- In case a single pump must be hoisted, fix the straps as follows:

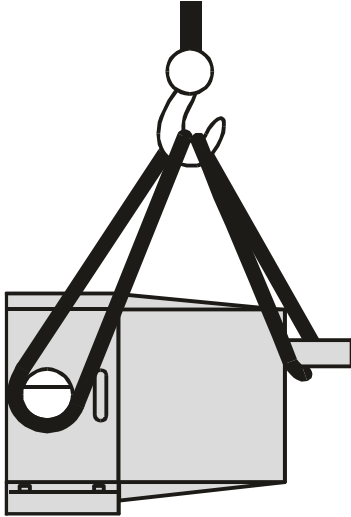

4.4. Safety



Never insert fingers into the rotor case or into the connection ports. Even manually rotating the shaft can cause injury!



If the risk exists of exceeding the maximum working pressure a safety device must be fitted to the pump, the drive or the system!

4.5. Foundation

- The foundation must be solid, flat and level.
- Take into consideration the need for draining facilities.
- The entire weight of the baseplate should rest level on the foundation. The baseplate **may not bend!**

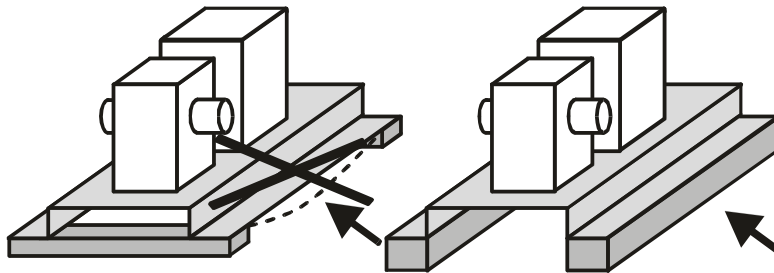

4.6. Built-in dimensions

- The proper built-in dimensions of the pump are incorporated in the dimensions sketch, supplied separately with the pump (-unit).
- See paragraph 9.2 for the main dimensions of the single pump.

4.7. Piping

The piping must meet the following requirements:

General

- Ensure the piping is sufficiently supported, especially besides the inlet and outlet ports. The piping should be fully supported independently from the pump.
- The connections must be fitted **square** to the pump.
- The lines must be fitted and connected **stress-free**.



Piping which is fitted obliquely, insufficiently supported or exerting force to the pump, may cause serious damage to the pump!

- Check if the piping shows any visible leakage.

Inlet piping

- It is recommended to place the pump **below** the supply liquid level. A flooded suction reduces the presence of air in the system.

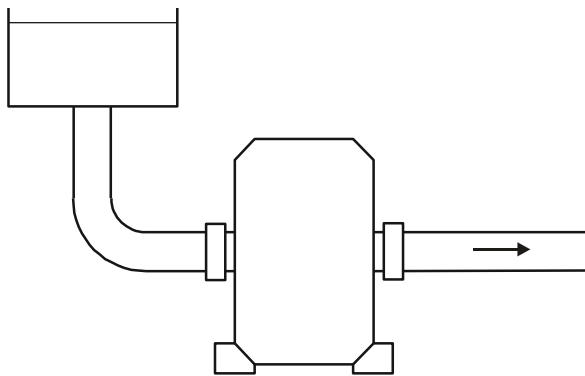

Non-return valves

- In case the pump is installed **above** the supply liquid level fit a non-return valve to the foot of the suction line to keep it filled with liquid. This applies especially when low-viscous liquids are conveyed.

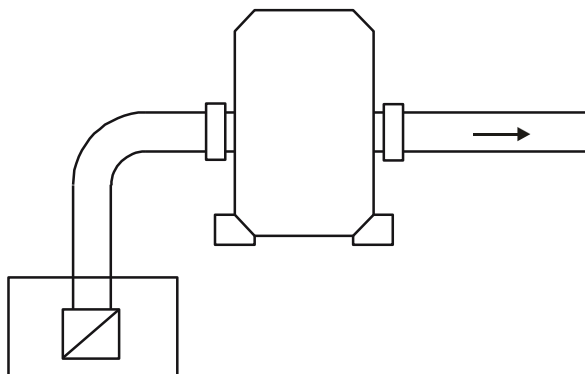

- For systems that convey liquid under vacuum, a non-return valve in the delivery line is recommended. This prevents backflow of air or liquid.

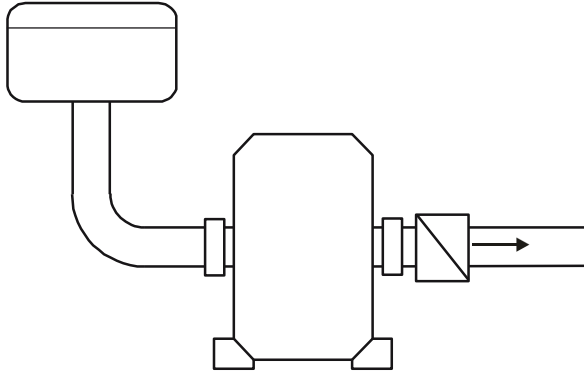

4.8. Pump with safety valve

If the pump is provided with a safety valve to the pump cover, it is **compulsory to install a pressure gauge at pressure side and a shut-off valve directly after the pressure gauge!**

- The pressure gauge must have a measuring range of at least 0-25 bar.

4.9. Pump-unit assembly

In case the pump is supplied as a single pump, it needs to be assembled to a drive and a baseplate.

Do the following:

1. Place the pump onto the baseplate and fit it with retaining bolts.
2. Fit a coupling half to the pump shaft.
3. Fit the other half to the drive shaft of the drive.
4. Fit the drive to the baseplate. Leave a 3 mm gap between both coupling halves.
5. Place copper shims under the feet of the drive to bring it on a level with the pump. Fix the drive.
6. Align the coupling according to the following instructions.

4.10. Coupling alignment

After the assembly and set-up of the pump-unit the alignment of the coupling needs to be checked.



Always check the alignment after hoisting the pump-unit up to its baseplate!

Misalignment can lead to excessive wear, increased motor temperature and noise level. Check the alignment, using special alignment equipment, or do the following:

1. Place a ruler on the coupling. It must be adjacent to the entire width of the coupling halves, see figure.
2. Repeat this check at 3 different positions around the coupling.
3. Check the alignment with a pair of outside callipers at 2 diametrically opposite positions of the coupling sides, see figure.
4. If the measured values are outside the tolerance limits, slightly loosen the retaining bolts of the drive and move the drive until the values are within their tolerance limits. Fix the retaining bolts again.
5. When the coupling is well aligned **mount the coupling guard.**

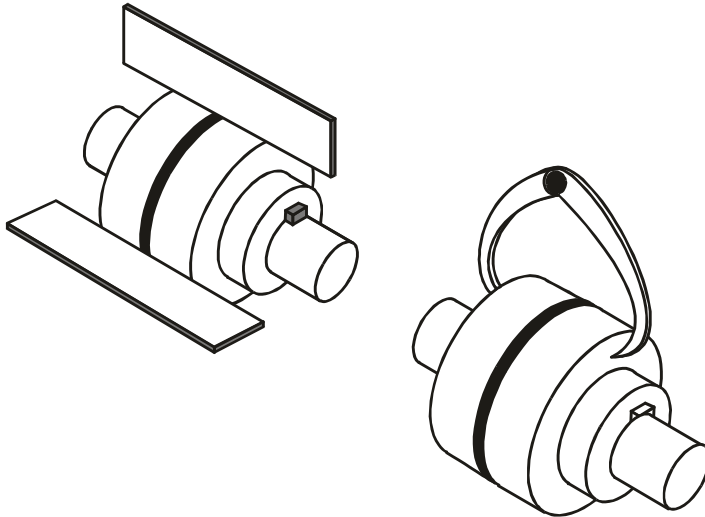

4.11. Alignment tolerances

The following table with its corresponding figure shows the tolerance limits for aligning the coupling.

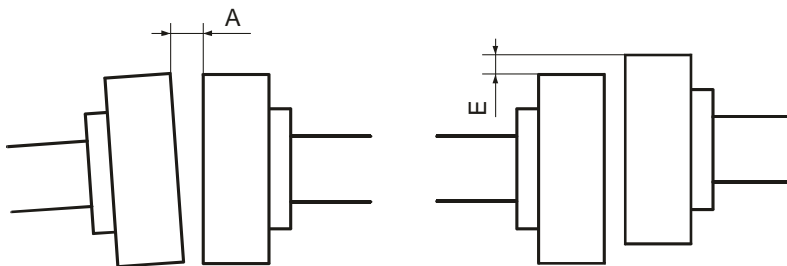

| Coupling outer diameter [mm] | A must be between [mm] | Max difference between A max and A min [mm] | E must be between [mm] |
|------------------------------|------------------------|---|------------------------|
| 81-95 | 2 - 4 | 0,15 | 0 - 0,15 |
| 96-110 | 2 - 4 | 0,18 | 0 - 0,18 |
| 111-130 | 2 - 4 | 0,21 | 0 - 0,21 |
| 131-140 | 2 - 4 | 0,24 | 0 - 0,24 |
| 141-160 | 2 - 6 | 0,27 | 0 - 0,27 |
| 161-180 | 2 - 6 | 0,30 | 0 - 0,30 |
| 181-200 | 2 - 6 | 0,34 | 0 - 0,34 |
| 201-225 | 2 - 6 | 0,38 | 0 - 0,38 |

4.12. Fitting additional connections



Ensure the engine cannot be started when work is performed to the pump-unit and the rotating parts are not completely covered!



Ensure that the whole system is thoroughly flushed and cleaned. The whole system must be free from debris and particles, because they could get into the pump and cause serious damage to rotors and rotor case!



A pump which is NOT equipped with a QUENCHED shaft seal (see type description), may NEVER be installed in a position where it possibly could run DRY!

Flushing

- When equipped with shaft seal type M1, M2 or O2: **Connect the flush pipes to the shaft seal chamber**, through the openings in the rotor case. The connections are threaded R1/8.
- In case a **low-pressure** quench (shaft seal types M2, M5, O2 and O4) is applied, the flushing system must have a capacity of **0,25 l/min at 0,5 mwc**. **In case the pump is vertically mounted the QUENCH SUPPLY LINE SHOULD BE CONNECTED TO THE LOWER SIDE!**
- In case a **pressurised** flush (shaft seal types M2 and M5) is applied, the pressure of the flushing system must be **2 bar** higher than system pressure. **In case the pump is vertically mounted the FLUSH SUPPLY LINE SHOULD BE CONNECTED TO THE LOWER SIDE!**

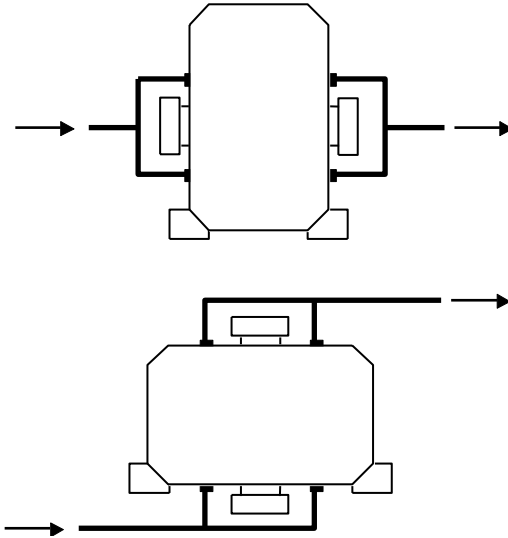

Heating

- When fitted with heating jackets: **connect this device to the heat supply**.

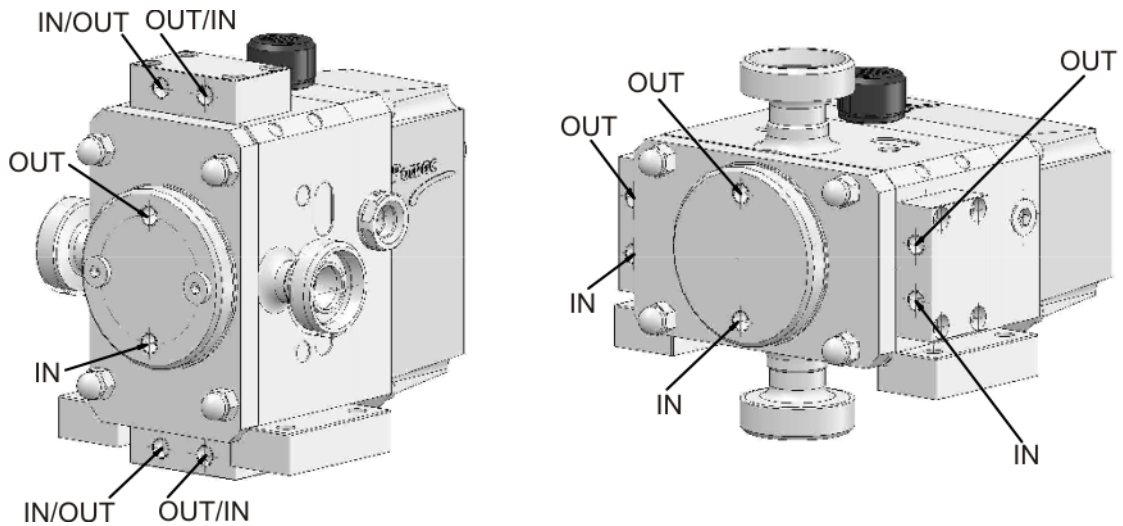

4.13. Flushing the system



The system must ALWAYS BE FLUSHED!

Not only BEFORE INSTALLING the pump, but AFTER EACH ACTIVITY DURING WHICH THE SYSTEM HAD TO BE OPENED, e.g. replacement of valves or piping segments!



If the pump is connected to the power supply: Ensure the pump is shut down and take precautions to prevent unintentional starting up of the pump!

See paragraph 9.4 for explanation of the item numbers.

1. Unscrew the cap nuts (1) and remove the front cover (3) and the O-ring (4).
2. Unscrew the rotor retainers (5) using the special spanner provided with the pump. Block the rotors against co-rotation using a proper fitting wooden or plastic dowel.
3. Remove the rotor retainers with O-rings (6).
4. Remove both rotors from the shafts.
5. Remove the shaft sleeves or the rotating seals part from the rotors and fit them in the dummy-rotors provided with the pump.
6. Fit the dummy-rotors to the shafts and fit the rotor retainers, using the special spanner.

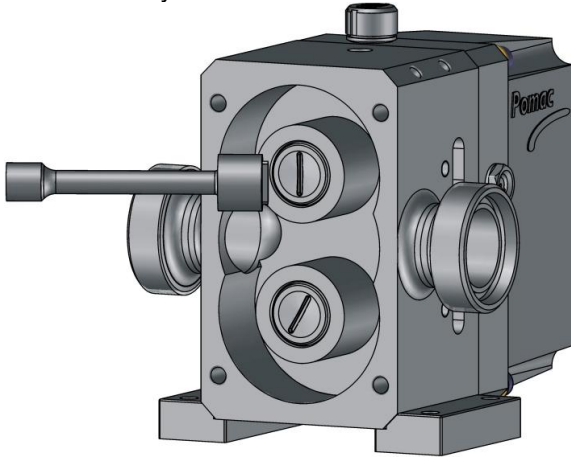

7. Fit the O-ring into the front cover and fit the front cover to the rotor case.
8. Thoroughly clean the entire system, from top to bottom. **Flush until the flushing liquid discharged from the system is clean and all debris is disposed of.**

Once the system is clean:

9. Unscrew the cap nuts and remove the front cover and the O-ring.
10. Remove the rotor retainers and remove both dummy-rotors from the shafts.
11. Remove the shaft sleeve or the rotating seal part from the dummy-rotors and refit them in the rotors.
12. Fit the rotors to the shafts, fit the O-rings and fit the rotor retainers with the proper torque, as indicated in the table below.

| Type | Torque rotor retainers [Nm] |
|--------|-----------------------------|
| PLP1 | 36 |
| PLP 15 | 36 |
| PLP2 | 62 |
| PLP3 | 155 |
| PLP4 | 300 |

13. Block the rotors against co-rotation using a proper fitting wooden or plastic dowel.

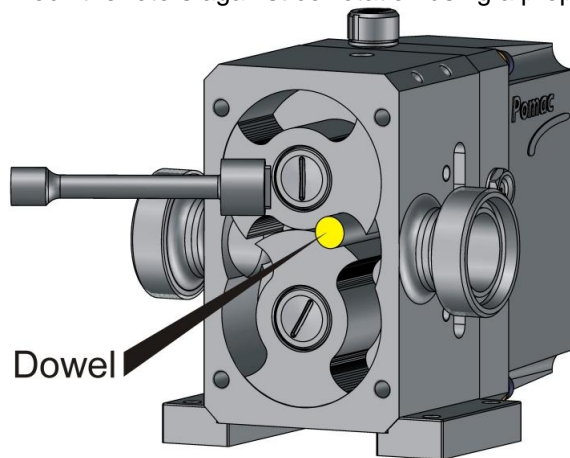

14. Fit the O-ring into the front cover and fit the front cover to the rotor case.

4.14. Establishing the direction of rotation



Never operate the pump without front cover or without being connected to the piping!

- Before connecting the drive to the power supply, the correct direction of rotation of the drive shaft must be established. The pump can operate in both directions. At the same time the drive shaft can have different positions. See following figure to establish the correct direction of rotation of the drive shaft.

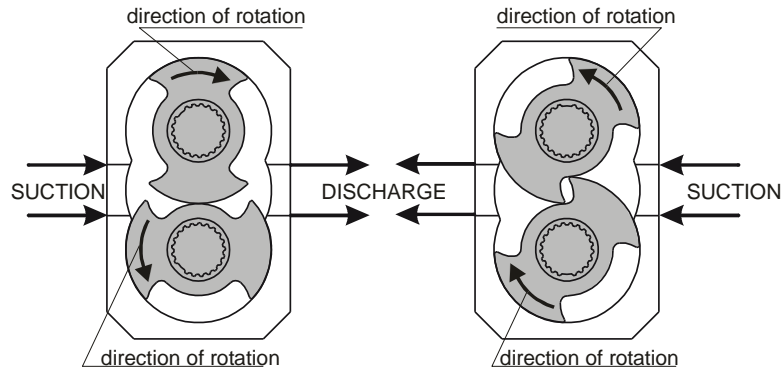

4.15. Connecting the drive



The pump may never be put into operation if the coupling is not provided with a properly fitting guard!

When driven by an **electric** drive:



An electric drive may only be connected to the electric power supply by a qualified electrician!

- Consult the locally prevailing regulations of the electricity company first, before connecting an electric drive!
- Fit an automatic circuit breaker to protect the drive against electrical overload.
- Mount a working switch close to the pump.
- Mount an earth switch.

4.16. Oil filling



The gearbox of a new pump is already filled with oil!

1. Unscrew the oil fill plug on top of the gearbox.
2. Fill the gearbox with oil until the oil level reaches the centre of the oil sight glass. See chapter 9 for the oil specifications.
3. Fit the oil plug to the gear box.

5. Operation

5.1. Checking

- Check if the gearbox is sufficiently filled with oil. The oil level must be visible through the oil sight glass of the gearbox.



The pump may never operate if the gearbox is not filled with oil!

- If present, check the pressure of the flushing system.
For shaft seals types M2, M5, O2 or O4 the (pressure-less) **quench** must have a pressure of **0,5 mwc and a flow of 0,25 l/min. In case the pump is vertically mounted the QUENCH SUPPLY LINE SHOULD BE CONNECTED TO THE LOWER SIDE!**
For shaft seals M2 or M5 the (pressurized) **flush** must have a pressure of **2 bar higher than system pressure.**
In case the pump is vertically mounted the FLUSH SUPPLY LINE SHOULD BE CONNECTED TO THE LOWER SIDE!
- If present, check if the heating system has the correct temperature.

5.2. Start Up

1. If present, open the stop valves of the flush lines.
2. If present, open the stop valves of the heating system. **Let the pump warm up to its working temperature.**
3. If present, open the discharge valve.
4. If present, open the suction valve.
5. Start the pump-unit.

5.3. Adjusting the safety valve



If the pump is provided with a safety valve, the required opening pressure of this valve must be set first BEFORE commissioning the pump!

5.3.1. Adjusting a spring loaded safety valve

1. Ensure the shut-off valves in the pressure line, and possibly in the suction line, are completely opened. The system must be filled with the liquid to be pumped.
2. Ensure the spring of the safety valve is **completely unloaded**. If not, unscrew the locknut and turn the setscrew completely **clockwise** (see figure) until the spring is completely unloaded.
3. Switch on the pump.
4. Turn the setscrew of the safety valve completely anti-clockwise until the spring is maximally loaded.



**On doing this, check if the pressure does not exceed 15 bar!
If it does exceed 15 bar, immediately shut down the pump and check the system piping!**

5. Slowly close the shut-off valve at pressure side until the pressure gauge indicates the desired opening pressure of the safety valve.



The opening pressure may never be set higher than 15 bar!

6. Turn the setscrew of the safety valve **clockwise** until the pressure gauge indicates the pressure starts decreasing. The valve is now set to the correct pressure.
7. Set the pressure shut-off valve to the normal opened position.
8. Fix the setscrew of the safety valve by tightening the locknut.

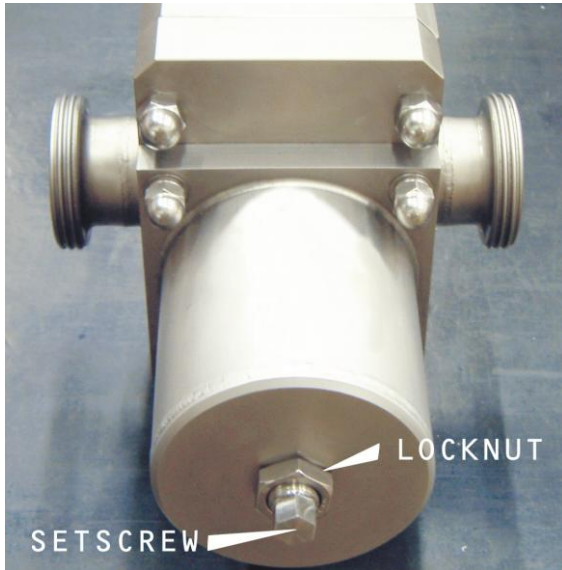

5.3.2. Adjusting an air loaded safety valve

1. Ensure the shut-off valves in the pressure line, and possibly in the suction line, are completely opened. The system must be filled with the liquid to be pumped. Install a pressure gauge in the pressure line between pump and shut-off valve.
2. Ensure there is **no air pressure** applied to the safety valve .
3. Switch on the pump.
4. Slowly apply a maximum of 5 bar air pressure to the safety valve.



Meanwhile, check if the pressure does not exceed the maximum pressure of the pump! If it exceeds the maximum pressure of the pump, immediately shut down the pump and check the system piping!

5. Slowly close the shut-off valve at pressure side until the pressure gauge indicates the desired opening pressure of the safety valve.



The opening pressure may never be set higher than the maximum pressure of the pump!

6. Decrease the air pressure until the pressure gauge indicates the pressure starts decreasing. The valve is now set to the correct pressure.
7. Reset the pressure shut-off valve to the normal opened position.



Use a monitoring device to check the setting of the air pressure continuously. If the pressure is rising or dropping a warning signal has to be given to the operator of the pump to stop the pump immediately !!!

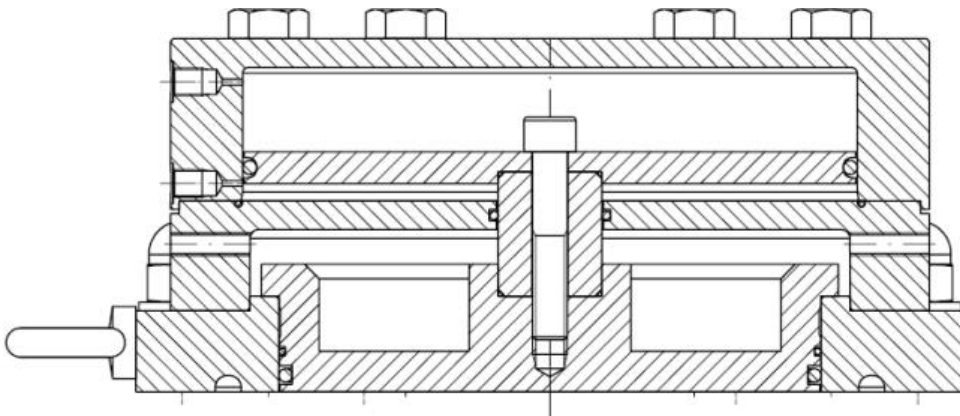

5.4. In operation



Never operate a pump with a shut-off discharge valve or a blocked discharge line, if no pressure relief valve is fitted!



If a pressure relief valve is fitted, do not allow the pump vent through it for long! A pressure relief valve is a safety device and not a flow control!



Avoid extreme temperature fluctuations of the pumped liquid. These may cause damage to the pump because of expanding/shrinking of pump parts.



The maximum values given for pressure, speed or temperature may never be exceeded!

5.5. Operating principle of the safety valve

In case a safety valve is mounted:

If the pump operated with a closed pressure valve, the pumped liquid is by-passed via the opened safety valve. A relatively small quantity of liquid will circulate constantly and the heat, generated by the internal liquid friction, is no longer evacuated to outside. The liquid temperature will increase strongly and the maximally permitted liquid temperature may be exceeded.



If a safety valve is mounted, do not let the pump circulate for too long! A safety valve is a safety device and may never be used as control valve!

Under normal system conditions the valve must remain closed. When the safety valve has been put into operation, a deviation of the normal conditions has occurred. Always find the cause of this and take proper measures!

5.6. Shutting down



Ensure that the pump does not run dry when emptying it! Dry running is only permitted if the pump is equipped with a flushed shaft seal!

1. Shut down the pump by shutting down the power supply to the drive.
2. In case the system remains pressurized, keep stop valves in flush lines OPEN.
3. If the pump is equipped with heating jackets, keep stop valves in the heating system OPEN in case the pump conveys a liquid that may congeal at lower temperatures.

6. Maintenance

6.1. General survey

Check regularly:

- if the pump functions properly.
Excessive noise may indicate problems like worn-out bearings, gear trouble, dragging of the rotors or cavitation.
- if applicable: pressure and flow of the **flushing system**.
- if applicable: the temperature of the **heating system**.
- the oil level. When the oil level has been reduced, check the pump for oil leakage.
- the pressure at suction- and delivery side.

6.2. Oil change

- Change the oil in the gearbox every 3000 operating hours, or at least once a year. See paragraph 9.1 for oil specifications

7. Disassembly / assembly

7.1. Ordering spare parts

When ordering spare parts the following information must be supplied:

- the **serial number**: this can be found on the pumps' type plate and on the first page of this manual
- the **type code**: this can be found on the pumps' type plate and on the first page of this manual.
- the item numbers; the numbers and - when known - the parts numbers of the required parts.

Chapter 9 shows a sectional drawing and parts list of the pump, with the item numbers referred to.



Rotors and gears are always supplied in pairs.

7.2. Safety measures



Never allow the pump to run without the front cover or without being connected to the piping!



Ensure the drive is shut down when performing maintenance work. Prevent it from being switched on again unintentionally!



Wear protective gloves and safety glasses in case the pump conveys liquids which are a health hazard!



Ensure the pump is depressurized when it has to be disassembled in order to carry out maintenance!



Allow the pump to cool down first when a heating jacket is fitted or when it conveys hot liquids!



Disassembly of a safety valve may ONLY be done WITH SPRING PRESSURE RELEASED, on a shut down pump, which is cooled down and vented!

7.3. Special tools

Rotor retainer spanner

| Type | Rotor retainer spanner |
|--------|------------------------|
| PLP 1 | 700-135.000 |
| PLP 15 | 700-135.000 |
| PLP 2 | 700-235.000 |
| PLP 3 | 700-335.000 |
| PLP 4 | 700-435.000 |

Dummy rotor

| Type | Dummy rotor |
|--------|-------------|
| PLP 1 | 700-112.000 |
| PLP 15 | 700-512.000 |
| PLP 2 | 700-212.000 |
| PLP 3 | 700-312.000 |
| PLP 4 | 700-412.000 |

7.4. Draining the pump

1. Close the stop valves at discharge and suction side of the pump. In case no stop valves are fitted, ensure that the system is drained to a level below the pump.
2. Place a collecting tank at the front of the pump, underneath the rotor case.
3. **Slacken** the cap nuts of the front cover.
4. Remove the cover from the rotor case, using the lever slots in the cover and a large screwdriver as a lever.
5. Collect the liquid emerging from the rotor case into the collecting tank.
6. Tighten the cap nuts again by hand.

7.5. Oil draining

1. Place a collecting tank below the oil drain of the gearbox.
2. Unscrew the vent plug at the top of the gearbox.
3. Unscrew the drain plug at the bottom of the gearbox and drain the oil.
4. Drain the oil in the collecting tank.
5. Fit the drain plug and the vent plug to the gearbox.



Ensure that oil does not leak into the environment!

7.6. Dismantling the pump

1. Remove the coupling guard.
2. Loosen the coupling half on the pump shaft and pull it backwards.
3. If present, loosen the quench pipes from the shaft seal.
4. If present, loosen possible connections to a safety relief valve.
5. If present, loosen the steam piping from the heating jacket.



Ensure the steam supply is shut down and the heating jackets have cooled down!

6. Loosen the connections of the discharge and suction ports. **Ensure the piping is sufficiently supported!**
7. Remove the retaining bolts and remove the pump from the baseplate. **Pump types PLP 2, 3 and 4 are too heavy to lift by hand. Use a proper hoisting device.** See paragraph 4.3 for hoisting instructions.

7.7. Pump disassembly



See the sectional drawing with parts lists in paragraph 9.4 for explanation of the item numbers.

1. Place the pump on a work bench fit to carry the weight of the pump.



There may still be residual product in the pump or residual oil in the gearbox. Pay attention to this and place the pump in e.g. a shallow collecting tank.

Rotor disassembly

2. Remove the cap nuts (1) and remove the front cover (3) and the O-ring (4).
3. Unscrew the retainers (5), using the key provided and remove the retainers with O-rings (6).

4. Block the rotors against co-rotation using a proper fitting wooden or plastic dowel.

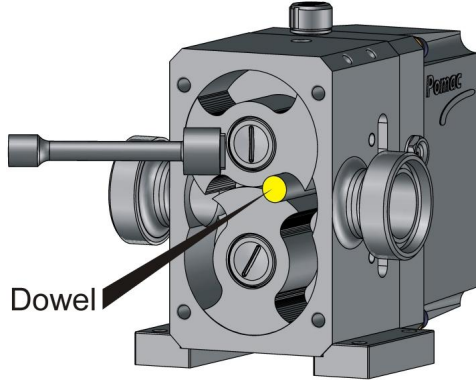

5. Remove both rotors (35) from the shafts.

Shaft seal disassembly

6. The rotary seal faces of the mechanical seals are fitted in the slots in the rotors already disassembled. Remove these parts by lifting them **carefully** with e.g. a screwdriver.



Extreme care should be taken when carrying out this procedure! Never use any percussive tools and do not make hammer-like movements with the screwdriver!



Do the following to disassemble the other parts of the shaft seal.

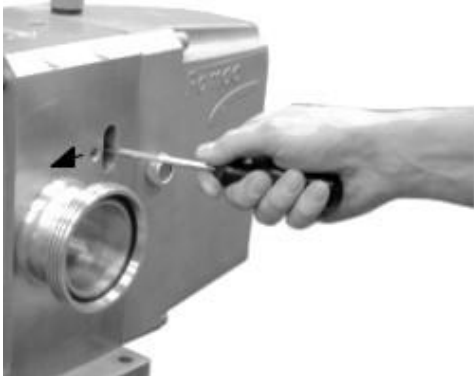

7. On either side of the shaft insert a screwdriver into the holes in the sides of the rotor case, see figure.
8. Place the tip of the screwdriver behind the tabs of the seal seat showing in the holes.
9. Carefully wriggle the seal seat with the shaft seal forward from the rotor case using both screwdrivers at the same time.
10. Remove the seal seat with the shaft seal from the pump shaft.
11. Remove the other shaft seal in the same way.



Keep both matching faces of a mechanical seal together when the mechanical seal is disassembled, the faces have run in on each other and they may not be switched around!

Gearbox disassembly

Proceed as follows to disassemble the gearbox.

12. Remove the key (22) from the drive shaft (23).
13. Remove the Allen screws (31) and remove the gearbox cover (28) from the rotor case.
14. Remove the gasket (11).
15. Remove the Allen screws (14) and remove both bearing cartridges (15) with shafts (23) and (30).
16. Remove the shims (12). **Mark the shims and their respective positions on the rotor case with waterproof marker. In case no parts have to be replaced these shims must be replaced in their original positions!**
17. Remove the oil retainer (10).
18. Remove the Allen screws (9) and remove the seal covers (8).

Bearing disassembly

Proceed as follows to disassemble the bearing assembly:

19. Loosen both bearing lock nuts (20) and remove these together with tab washers (19).
20. Remove the gears (17) and (29) from the shafts.
21. Block the bearing cartridge and remove the shaft with the bearings by tapping on the shaft end at drive side **with a plastic hammer**.
22. Pull the smaller bearing (16) from the shaft, using a proper puller.
23. Use a proper fitting bush, its bore larger than the shaft shoulder and bearing on the inner ring of the larger bearing (13), and tap this bearing from the shaft.
24. Remove both bearing shells from the bearing cartridges.

7.8. Disassembly of a safety valve



Disassembly of a safety valve may ONLY be done on a shut down pump, which is cooled down and vented!

7.8.1. Disassembly of a spring loaded safety valve



For explanation of the item numbers see the sectional drawing and parts list in paragraph 9.9.

1. Unscrew locknut (12).
2. Turn set screw (11), to set the spring load, with a properly fitting spanner entirely **CLOCKWISE** until the spring is completely unloaded!
3. Unscrew the 4 fixation nuts (8) of the safety valve.
4. Remove the safety valve casing (6) with spring (9).
5. Unscrew the cap nuts of the pump cover (1) and remove the pump cover with the plunger (3) from the pump.
6. Push the plunger out of the opening in the cover.
7. Remove the O-ring (2) from the plunger.

7.8.2. Disassembly of an air loaded safety valve



For explanation of the item numbers see the sectional drawing and parts list in paragraph 9.10.



Disassembly of a safety valve may ONLY be done on a shut down pump, which is cooled down and vented!

1. Shut off the air pressure and vent the compressed air supply line.
2. Disconnect the compressed air connection.
3. Unscrew the fixation bolts (7) of the safety valve.
4. Remove the complete safety valve casing.
5. Unscrew the Allen screw (14) and disassemble the interior parts of the safety valve.
6. Remove the O-rings.
7. Unscrew the cap nuts of the pump cover and remove the pump cover from the pump.

7.9. Parts inspection

- Replace defective parts always using **original Pomac parts**.
- Check all oil retainers for possible leakages.
- Check all non-defective parts for scratches, burrs, debris or excessive wear.
- In case the gearbox has been disassembled: Make sure the sealing face between rotor case and gearbox cover is clean and free from gasket remains.
- Clean all parts with a non picking cloth.

7.10. Gearbox assembly



See the sectional drawing with parts list in paragraph 9.4 for explanation of the item numbers. For the shaft seals see paragraph 9.7.



If the pump is provided with QUATTRO LOBES, the LOBE TIMING must always be readjusted after every occasion the bearings have been disassembled! See paragraph 7.14 !



Ensure all parts are clean and the working area is cleaned up!

1. Fit the large and small bearing shells at both sides into the bearing cartridges (15).



2. Heat the larger bearings (13) and fit these to the shafts. Push the bearings firmly and **let them cool down.**
3. Put the shaft vertically on the spline side and place the bearing cartridge with the bearing shells onto the shaft.
4. Heat the smaller bearings (16) and fit these to the shafts. Push the bearings firmly and **let them cool down.**
5. Fit a key (18) in each shaft. See following table for the correct dimensions.

| Type | Size | Length |
|--------|-------|--------|
| PLP 1 | 6x6 | 15 mm |
| PLP 15 | 8x7 | 20 mm |
| PLP 2 | 10x8 | 25 mm |
| PLP 3 | 14x9 | 42 mm |
| PLP 4 | 20x12 | 55 mm |

If quattro lobes are mounted:

6. Place the gear ring over the hub of the adjustable gear. Ensure the key way in the hub and the marks on the gear ring are placed **opposite to each other** (so the key way at "12 o'clock" and the marks at "6 o'clock")
7. Apply a drop of oil on the Allen screws and screw them into the gear ring. Tighten the Allen screws **by hand.**
8. Fit the gears (17 and 29) to the shafts, its marks facing towards the rear side (drive side). The gear with **right hand helix (17) has 2 marks** and must be fitted to the **drive shaft (23)**. The gear with **left hand helix (29) has 1 mark** and must be fitted to the **lay shaft (30)**.



9. Fit a tab washer (19) to each shaft.
10. Fit the lock nuts (20) to the shafts. Tighten them to the correct torque, see following table:

| Type | Torque [Nm] |
|--------|-------------|
| PLP 1 | 1,3 Nm |
| PLP 15 | 1,8 Nm |
| PLP 2 | 2,0 Nm |
| PLP 3 | 3,0 Nm |
| PLP 4 | 5,8 Nm |

11. Fix the lock nut by tapping a tab of the tab washer into an opening of the lock nut.
12. Fit the seal covers (8) into the rotor case (34), the seal compartment facing the front side (pump side), see following figure.
13. Fit the oil retainers (10) into the rotor case, see following figure.



14. Fit a bearing cartridge (15) to the rotor case, using Allen screws (14).
15. Fit the second bearing cartridge to the rotor case, using Allen screws. **Ensure the marks on the gears correspond with each other!**
16. Place the shims (12) underneath the bearing cartridges in their original positions as marked on the rotor case.
17. Fix the Allen screws of the bearing cartridges.

7.11. Adjusting the axial rotor clearance

The clearance between the rotor and the rotor case must be adjusted again in case one or more of the following parts have been replaced:

- shaft
- pump casing
- bearing
- bearing cartridge

Do the following:

1. Fit a bearing cartridge (15) into the rotor case bore with Allen screws (14). Fix the bearing cartridge temporarily with 2 screws.
2. Fit the other bearing cartridge into the rotor case bore with Allen screws. **See to it that the markings correspond to each other.** Fix this bearing cartridge also temporarily with 2 screws.

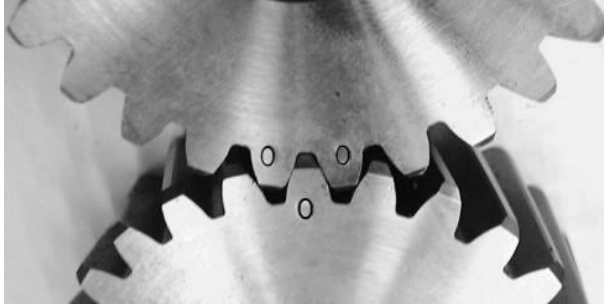

3. Measure the depth of the rotor case.
4. Measure the distance between the front of the rotor case and the shaft shoulder against which the rotor will rest.
5. The difference between both dimensions is called **X**.
6. Place the required thickness of shims (12) between the rotor case and the bearing cartridge flange to get the clearance **B** (see table and figure below) within its required clearance limits.
Total shim thickness = X - B

| Type | Clearance B |
|--------|---------------|
| PLP 1 | 0,10 -0,12 mm |
| PLP 15 | 0,12 -0,15 mm |
| PLP 2 | 0,15 -0,17 mm |
| PLP 3 | 0,18 -0,20 mm |
| PLP 4 | 0,25 -0,29 mm |

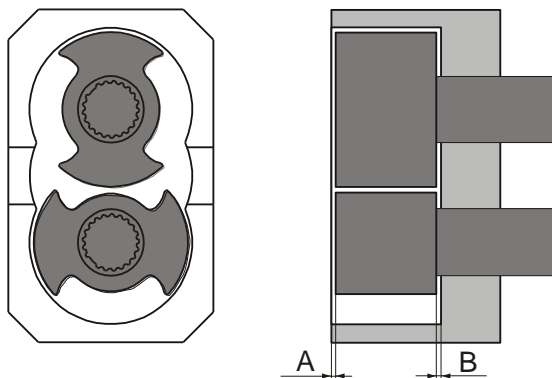

7. Fix the rotors (35) onto the shaft.

8. Check both to ensure clearance A comes within the following values:

| Type | clearance A |
|--------|------------------|
| PLP 1 | 0,08 - 0,14 mm |
| PLP 15 | 0,095 - 0,175 mm |
| PLP 2 | 0,12 - 0,20 mm |
| PLP 3 | 0,15 - 0,23 mm |
| PLP 4 | 0,25 - 0,43 mm |

| Bolts of bearing bracket and pump casing | | Tightening torque [Nm] |
|--|--------|------------------------|
| PLP 1 | M6x25 | 7,5 Nm |
| PLP 15 | M8x35 | 20 Nm |
| PLP 2 | M10x45 | 36 Nm |
| PLP 3 | M12x60 | 63 Nm |
| PLP 4 | M16x70 | 155 Nm |

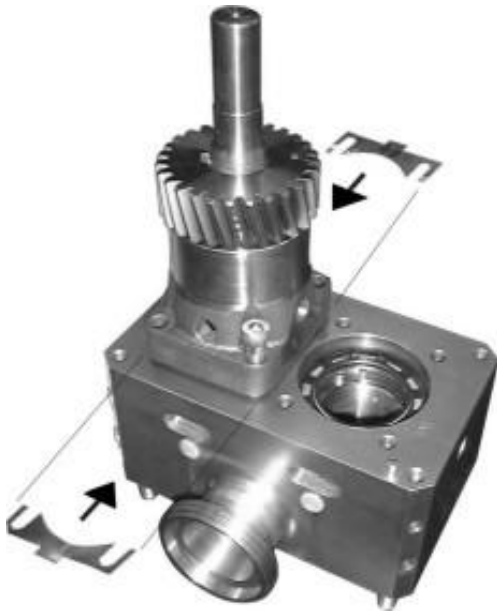

9. If clearance A does not correspond with these values, add or remove a shim.
10. When the clearances A and B are within their limits, tighten all bearing cartridge bolts.
11. Disassemble the rotors.

7.12. Shaft seal assembly

7.12.1. Single mechanical seal assembly, types M1, M3 and M4

See paragraph 9.5.1 for drawing and part list with item numbers.

1. Fit the seal seat (7F) into the rotor case. The tabs of the bush must fit into the slots of the seal cover.
2. Fit the wave spring (7E) onto the pump shaft.
3. Fit the stationary seal face (7C) with its O-ring (7D) over the pump shaft into the rotor case.
Ensure that the co-rotation pins fit into the slots of the seal ring!

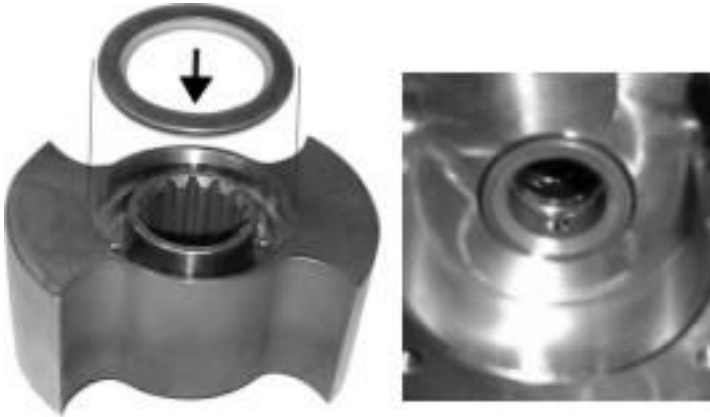

4. Fit the rotating seal ring (7A) with its O-ring (7B) into the rotor. **Ensure that the co-rotation pins fit into the slots of the seal ring!**
5. Fit the rotor, see 7.12.

7.12.2. Double mechanical seal assembly, types M2 and M5

See paragraph 9.5.2 for drawing and part list with item numbers.

1. Fit the rotating seal face (7J) with its O-ring (7K) onto the pump shaft. **Ensure that the co-rotation pins on the shaft fit into the slots of the seal ring!**
2. Fit the stationary seal face (7I) with its O-ring (7H) over the pump shaft.
3. Fit the seal seat (7F) with its O-ring (7G) into the pump casing. The tabs of the bush must fit into the slots of the seal cover.
4. Fit the wave spring (7E) onto the pump shaft.
5. Fit the stationary seal face (7C) with its O-ring (7D) over the pump shaft into the rotor case.
Ensure that the co-rotation pins correspond to the gaps of the seal ring!
6. Fit the rotating seal face (7A) with its O-ring (7B) to the rotor. **Ensure that the co-rotation pins fit into the slots of the seal ring!**
7. Fit the rotor, see 7.12.

7.12.3. O-ring seal assembly, types O1, O2, O3 and O4

See paragraphs 9.5.3 and 9.5.4 for drawings and part lists with item numbers.

1. Fit the O-ring(s) (7C) into the seal seat (7F)
2. Fit the seal seat with its O-ring(s) (7G) into the rotor case. The tabs of the bush must fit into the slots of the seal cover.
3. Fit the shaft sleeve (7A) with its O-ring (7B) into the rotor. **Ensure that the co-rotation pins fit into the slots of the shaft sleeve!**
4. Fit the rotor, see 7.12.

7.12.4. Lip seal assembly, type L

See paragraph 9.5.5 for drawing and part list with item numbers.

1. Fit the seal seat (7F) into the rotor case. The tabs of the bush must fit into the slots of the seal cover.
2. Fit the lip ring (7C) over the pump shaft into the rotor case.
3. Fit the shaft sleeve (7A) with its O-ring (7B) into the rotor. **Ensure that the co-rotation pins fit into the slots of the shaft sleeve!**
4. Fit the rotor, see 7.12.

7.13. Rotor assembly

1. Fit the rotors onto the shafts.
2. Screw the rotor retainers with their O-ring into the shaft.
3. Tighten the bolts with the special bit, which is included in the delivery. For the **required Tightening Moment** refer to the table below:

| Type | Tightening Moment [Nm] |
|--------|------------------------|
| PLP 1 | 36 |
| PLP 15 | 36 |
| PLP 1 | 62 |
| PLP 3 | 155 |
| PLP 4 | 300 |

4. Block the rotors against co-rotation using a proper fitting wooden or plastic dowel.

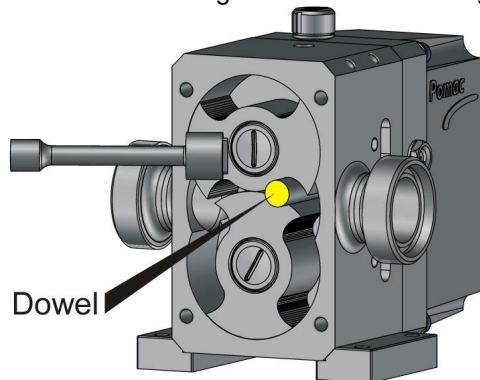

7.14. Adjusting the timing of 'quattro lobes'

If the pump is provided with so-called "quattro-lobes", they must be adjusted with regard to each other. Act as follows:

1. Ensure the Allen screws of the driven gear (see figure) **are not completely tightened**.

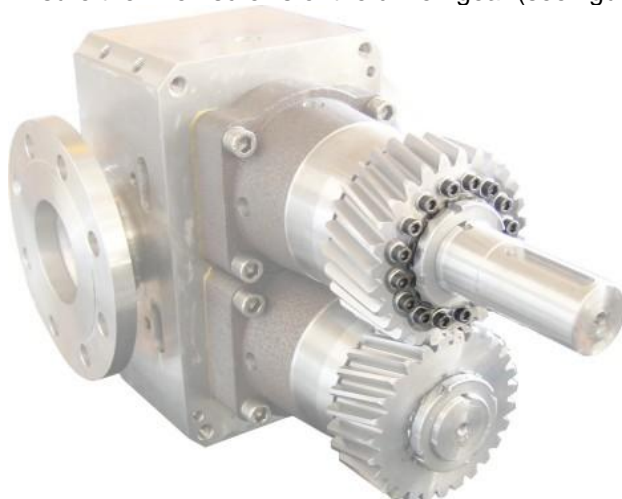

2. Rotate the pump shaft until the lobes are in the positions as shown below.

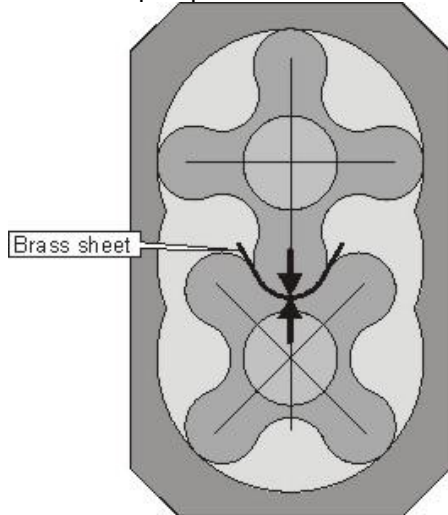

3. Measure the gap between the upper and lower rotor at the indicated spot, using a feeler gauge.
4. Place a strip of brass sheet, with the thickness of the measured gap, between both lobes. The lobes may no longer move with regard each other. If necessary use a thicker brass sheet.
5. Tighten the Allen screws of the screw ring **crosswise** with the prescribed torque as indicated below.

| PLP | Bolt | Quantity | Torque [Nm] |
|-----|------|----------|-------------|
| 1 | M4 | 8 | 4,9 |
| 15 | M5 | 10 | 9,8 |
| 2 | M5 | 10 | 9,8 |
| 3 | M6 | 16 | 16,8 |
| 4 | M10 | 12 | 81 |

6. Remove the strip of brass sheet.

7.15. Front cover assembly

See paragraph 9.4 for drawing and parts list of the referenced parts.

1. Place the O-ring (4) in the front cover (3).
2. Fit the front cover to the rotor case and fix it with cap nuts (1)
3. Fit -in case they are disassembled- the feet (32) with Allen screws (33).

7.16. Gearbox assembly

See paragraph 9.4 for drawing and parts list of the referenced parts.

1. Place a **new** gasket (11) into the gearbox cover (28).
2. Fit the gearbox cover to the rotor case with Allen screws (31).

In case they are disassembled, fit the parts as described below, into the gearbox. The positions are indicated starting at the back of the pump. **Attention: if the pump is mounted in a self-draining position, the gearbox is mounted in a FLAT position!**

3. Fit the plugs (27) into the holes at the bottom and right side of the gearbox
4. Fit the oil sight glass (24) into the hole at the left of the gearbox.
5. Fit the oil fill plug (25) into the hole on top of the gearbox.

7.17. Assembly of a safety valve

7.17.1. Assembly of a spring-loaded safety valve

See paragraph 9.9 for the drawing and parts list.

1. Put the pump cover flat down.
2. Lubricate the O-ring lightly with some food compatible grease, fit it around the plunger and push the plunger into the hole in the pump cover.
3. **Entirely** screw the pressure disk (10) onto setscrew (11).
4. Fit the pressure disk with the setscrew into the safety valve casing (6). The guiding pin must correspond to the hole in the pressure disk. Tighten the locknut (12) by hand.
5. Fit the spring onto the plunger.
6. Fit the safety valve casing over the spring. Fix it with cap nuts (8).
7. Fit the O-ring, mount the pump cover to the pump and fix it with the cap nuts.
8. The adjustment of the spring of the safety valve must be carried out on-site, during process conditions. See paragraph 5.3.

7.17.2. Assembly of an air-loaded safety valve

See paragraph 9.10 for the drawing and parts list.

1. Fit the O-rings (10) and (11) around the plunger (1), using some food compatible grease.
2. Put the plunger flat down and fit the spacer bush (2) in the plunger.
3. Fit the O-ring (9) inside the intermediate ring (4), using some food compatible grease.
4. Fit the intermediate ring to the spacer bush.
5. Fit the O-ring (12) around the piston (3), using some food compatible grease.
6. Fit the piston to the spacer bush and fit the Allen screw (14).
7. Put the pump cover flat down and place the entire subassembly in the pump cover.
8. Fit the O-ring (13) in the groove of the intermediate ring, using some food compatible grease.
9. Fit the safety valve casing (5) over the piston.
10. Fit the fixation screws (7) to fix the entire assembly to the pump cover.
11. Fit the O-ring, mount the pump cover to the pump and fix it with the cap nuts.
12. Setting the air pressure on of the safety valve must be carried out on-site, during process conditions. See paragraph 5.3.

7.18. Filling with oil

See paragraphs 9.1 and 9.2 for recommended oil types and quantities.

1. Unscrew the oil fill plug.
2. Fill the gearbox with oil till it shows at the centre of the oil sight glass.
3. Check the oil level after a couple of minutes.
4. Top up if necessary.
5. Fit the oil fill plug.

8. Closing down

8.1. Dismantling

See paragraph 7.6 for dismantling instructions.

8.2. Storage

- If the pump is going to be stored, the pump shaft must be rotated manually once a month.
- If the pump is to be stored for a long period of time, it must be done so on a vibration-free base.



If the pump, which is going to be stored is equipped with a safety valve: Prior to storage loosen the lock nut and turn the spring load set screw completely CLOCKWISE, using a proper spanner, until the spring load is completely released!

8.3. Disposal

If the pump is to be disposed of, take care of the following items:

- Clean the rotor case internally, it may still contain residual product.
- Drain the oil from the gearbox.
- Dispose of the pump using a company specialized in metal scrapping.

9. Technical data

9.1. Oil types

Recommended oil types for the gearbox are:

| Examples of recommended oil types | |
|--|----------------------|
| Make | Type |
| Shell | Cassida Fluid GL 220 |
| BP | Energol GR-FG 220 |

| Recommended characteristics | |
|------------------------------------|--------|
| Ambient temperature | Grade |
| -18 °C to 0 °C | EP 150 |
| 0 °C to 30 °C | EP 220 |
| 30 °C to 150 °C | EP 320 |

9.2. Oil quantities

| | Horizontally | Vertically |
|--------|--------------|------------|
| PLP 1 | 0,4 litre | 0,4 litre |
| PLP 15 | 0,6 litre | 0,65 litre |
| PLP 2 | 1,1 litre | 0,9 litre |
| PLP 3 | 3,1 litre | 3,3 litre |
| PLP 4 | 9,5 litre | 11,3 litre |

9.3. Dimensions

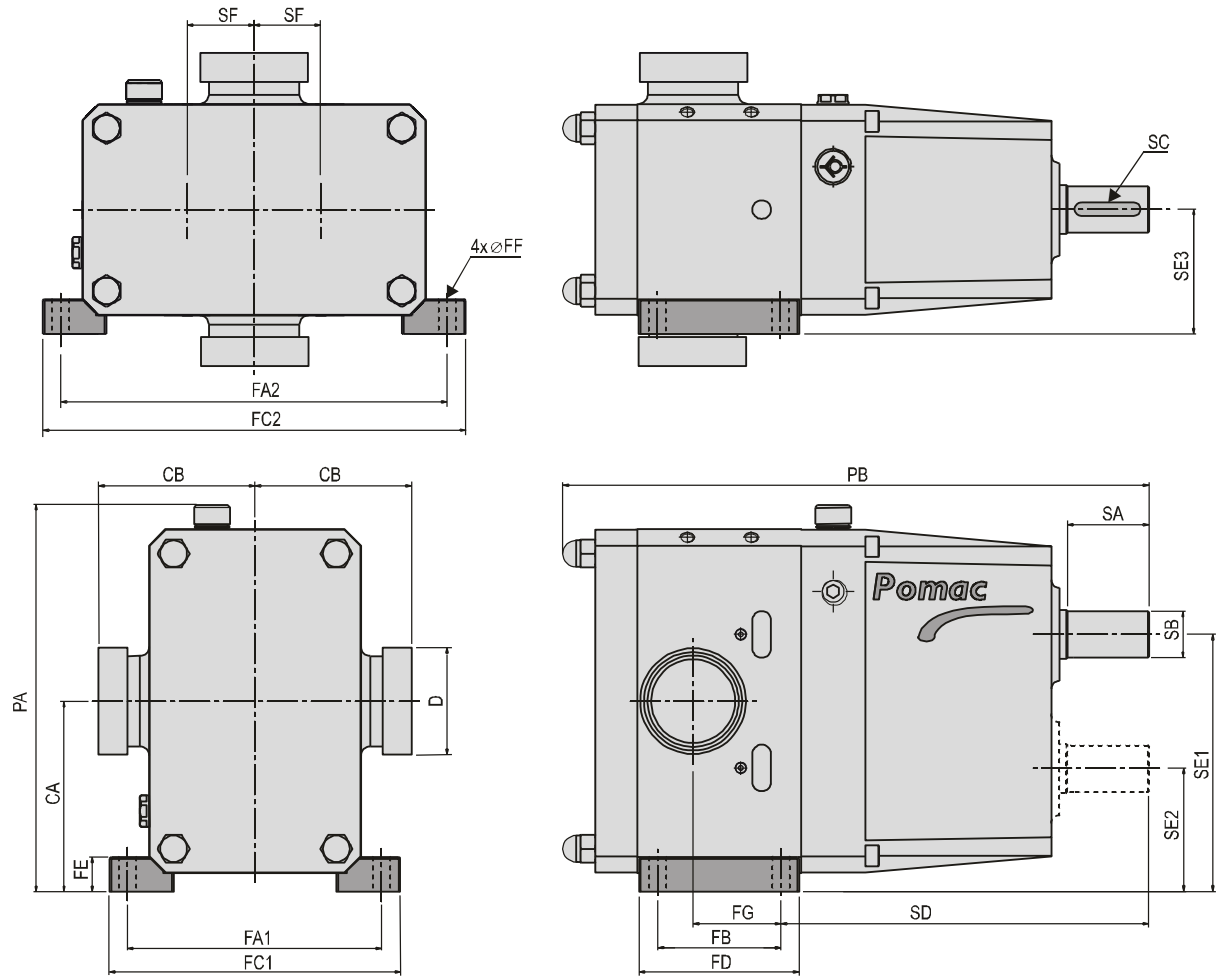

| TYPE | D | CA | CB | FA1 | FA2 | FB | FC1 | FC2 | FD | FE | FF | FG | PA | PB | SA | SB | SC | SD | SE1 | SE2 | SE3 |
|----------|------|-----|------|-----|-----|-----|-----|-----|-----|----|----|------|-------|-----|----|----|-------|-------|-------|-------|-----|
| PLP1-¾ | NW15 | 84 | 65,5 | 114 | 168 | 50 | 136 | 190 | 72 | 19 | 9 | 41,5 | 177,5 | 219 | 30 | 15 | 25x5 | 137 | 111,5 | 56,5 | 57 |
| PLP1-1 | 1" | 84 | 84 | 114 | 168 | 50 | 136 | 190 | 72 | 19 | 9 | 44,5 | 177,5 | 226 | 30 | 15 | 25x5 | 137 | 111,5 | 56,5 | 57 |
| PLP1-1,5 | 1,5" | 84 | 77,5 | 114 | 168 | 50 | 136 | 190 | 72 | 19 | 9 | 50,5 | 177,5 | 245 | 30 | 15 | 25x5 | 137 | 111,5 | 56,5 | 57 |
| PLP 15-2 | 2" | 97 | 106 | 132 | 194 | 50 | 154 | 216 | 72 | 19 | 9 | 57,5 | 203,0 | 295 | 45 | 20 | 40x6 | 172,5 | 129 | 65 | 66 |
| PLP2-1,5 | 1,5" | 123 | 111 | 162 | 248 | 80 | 190 | 276 | 106 | 24 | 11 | 57,5 | 253 | 344 | 48 | 25 | 40x8 | 219 | 165,5 | 80,5 | 80 |
| PLP2-2 | 2" | 123 | 113 | 162 | 248 | 80 | 190 | 276 | 106 | 24 | 11 | 62,5 | 253 | 355 | 48 | 25 | 40x8 | 219 | 165,5 | 80,5 | 80 |
| PLP2-2,5 | 2,5" | 123 | 118 | 162 | 248 | 80 | 190 | 276 | 106 | 24 | 11 | 67 | 253 | 367 | 48 | 25 | 40x8 | 219 | 165,5 | 80,5 | 80 |
| PLP3-2 | 2" | 164 | 141 | 218 | 332 | 106 | 250 | 364 | 138 | 30 | 13 | 63 | 334 | 468 | 70 | 40 | 60x12 | 317 | 221,5 | 106,5 | 107 |
| PLP3-3 | 3" | 164 | 135 | 218 | 332 | 106 | 250 | 364 | 138 | 30 | 13 | 75,5 | 334 | 498 | 70 | 40 | 60x12 | 317 | 221,5 | 106,5 | 107 |
| PLP3-4 | 4" | 164 | 160 | 218 | 332 | 106 | 250 | 364 | 138 | 30 | 13 | 90,5 | 334 | 526 | 70 | 40 | 60x12 | 317 | 221,5 | 106,5 | 107 |
| PLP4-4 | 4" | 230 | 214 | 338 | 472 | 142 | 378 | 512 | 182 | 58 | 18 | 99,5 | 463 | 675 | 98 | 55 | 90x16 | 448 | 310 | 150 | 163 |

According to DIN 11851

9.4. Sectional drawing

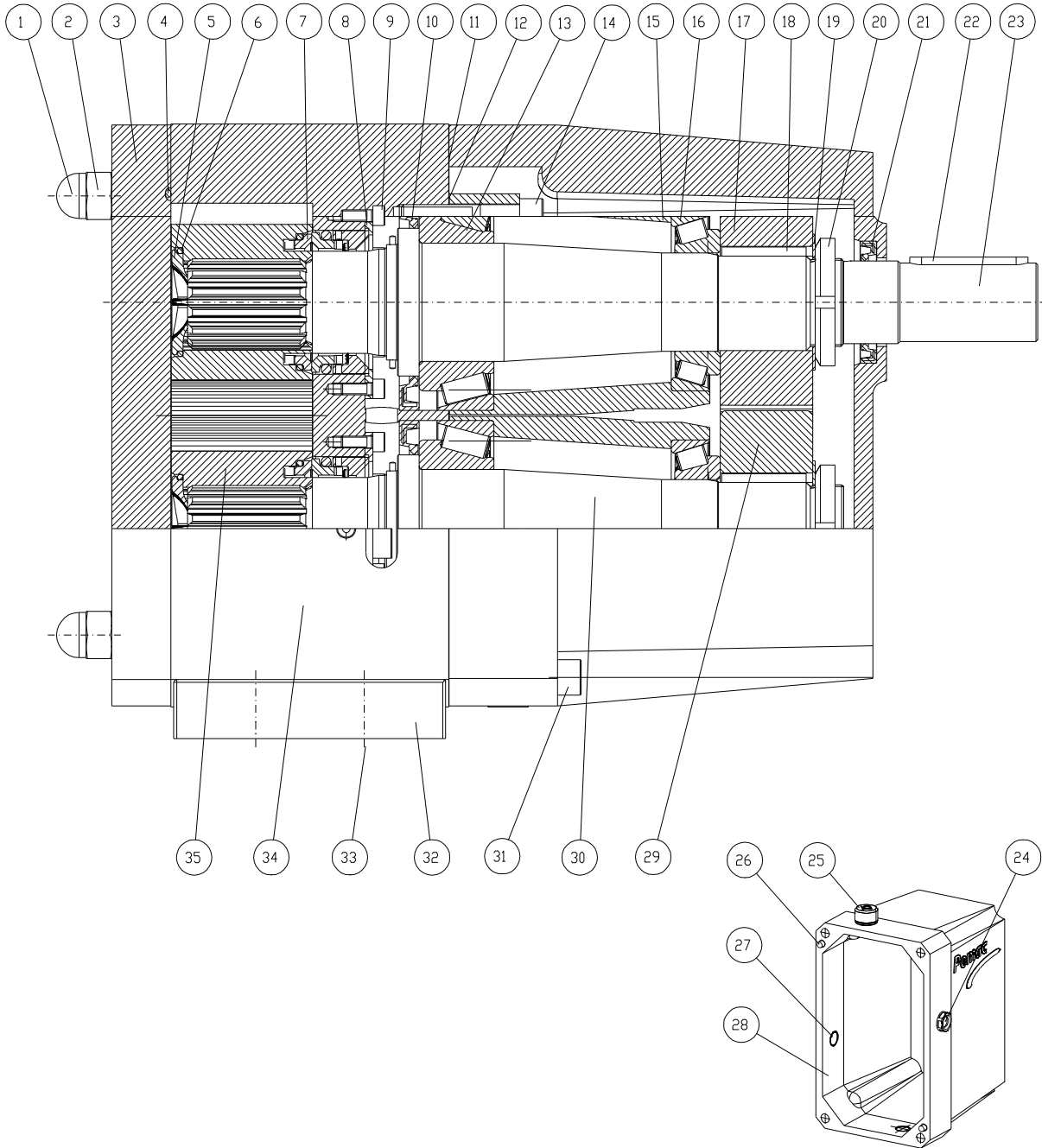

9.5. Parts lists

9.5.1. Part list with article numbers PLP 1

| ITEM. | QUANTITY | DESCRIPTION | ARTICLE NR. | | |
|-------|----------|-----------------------------|-------------------|-------------------|-------------------|
| | | | PLP 1-3/4 | PLP 1-1 | PLP 1-1 1/2 |
| 001 | 4 | Cap nut | 051.022-08-000-5 | 051.022-08-000-5 | 051.022-08-000-5 |
| 002 | 4 | Stud | 051.073-08-020-5 | 051.073-08-020-5 | 051.073-08-020-5 |
| 003 | 1 | Pump cover | 700.117-000 | 700.117-000 | 700.117-000 |
| 004 | 1 | O-Ring | 051.741-100034 | 051.741-100034 | 051.741-100034 |
| 005 | 2 | Rotor retainer | 700.118-000 | 700.118-000 | 700.118-002 |
| 006 | 2 | O-Ring | 051.741-100000 | 051.741-100000 | 051.741-100000 |
| 007 | | **shaft seal** | | | |
| 008 | 2 | Seal cover | 700.150-007 | 700.150-007 | 700.150-007 |
| 009 | 8 | Allen screw | 051.000-04-012-5 | 051.000-04-012-5 | 051.000-04-012-5 |
| 010 | 2 | Oil retaining ring | 051.763-012 | 051.763-012 | 051.763-012 |
| 011 | 1 | Gasket gearbox cover | 700.161-000-A | 700.161-000-A | 700.161-000-A |
| 012 | 4 | Shim | 700.160-000-A | 700.160-000-A | 700.160-000-A |
| 013 | 2 | Cone bearing | 051.658-028-007 | 051.658-028-007 | 051.658-028-007 |
| 014 | 8 | Allen screw | 051.000-06-025-5 | 051.000-06-025-5 | 051.000-06-025-5 |
| 015 | 2 | Bearing cartridge | 700.115-000-B | 700.115-000-B | 700.115-000-B |
| 016 | 2 | Cone bearing | 051.658-022-008 | 051.658-022-008 | 051.658-022-008 |
| 017 | 1 | Right hand gear | 700.120-000-B | 700.120-000-B | 700.120-000-B |
| 018 | 2 | Key | 051.607-06-015-10 | 051.607-06-015-10 | 051.607-06-015-10 |
| 019 | 2 | Tab washer | 051.670-020-000 | 051.670-020-000 | 051.670-020-000 |
| 020 | 2 | Lock nut | 051.669-020-000 | 051.669-020-000 | 051.669-020-000 |
| 021 | 1 | Oil retaining ring | 051.763-013 | 051.763-013 | 051.763-013 |
| 022 | 1 | Key | 051.607-05-025-00 | 051.607-05-025-00 | 051.607-05-025-00 |
| 023 | 1 | Drive shaft | 700.113-002 | 700.113-000-C | 700.113-001 |
| 024 | 1 | Oil sight glass | 054.210-012 | 054.210-012 | 054.210-012 |
| 025 | 1 | Oil fill plug with breather | 054.211-010 | 054.211-010 | 054.211-010 |
| 026 | 2 | Cylindrical pin | 051.074-050-010-6 | 051.074-050-010-6 | 051.074-050-010-6 |
| 027 | 2 | Plug | 054.108-031-3 | 054.108-031-3 | 054.108-031-3 |
| 028 | 1 | Gearbox cover | 700.116-000 | 700.116-000 | 700.116-000 |
| 029 | 1 | Left hand gear | 700.121-000-B | 700.121-000-B | 700.121-000-B |
| 030 | 1 | Lay shaft | 700.114-002 | 700.114-000-C | 700.114-001 |
| 031 | 4 | Allen screw | 051.000-06-040-5 | 051.000-06-040-5 | 051.000-06-040-5 |
| 032 | 2 | Foot | 700.132-000 | 700.132-000 | 700.132-000 |
| 033 | 4 | Allen screw | 051.000-08-020-5 | 051.000-08-020-5 | 051.000-08-020-5 |
| 034 | 1 | Rotor casing | 700.110.007 | 700.110.005 | 700.110.012 |
| 035 | 2 | Rotor | 700.111-007 | 700.111-000 | 700.111-006 |

User manual Pomac PLP Lobe pump

9.5.2. Part list with article numbers PLP 15

| ITEM. | QUANTITY | DESCRIPTION | ARTICLE NR. |
|-------|----------|-----------------------------|-------------------|
| | | | PLP 15-2 |
| 001 | 4 | Cap nut | 051.022-10-000-5 |
| 002 | 4 | Stud | P-000-001-527 |
| 003 | 1 | Front cover | 700.517-000 |
| 004 | 1 | O-Ring | P-000-001-524 |
| 005 | 2 | Rotor retainer | 700.118-000 |
| 006 | 2 | O-Ring | 051.741-100000 |
| 007 | | **shaft seal** | |
| 008 | 2 | Seal cover | 700.150-007 |
| 009 | 8 | Allen screw | 051.000-04-012-5 |
| 010 | 2 | Oil retaining ring | P-000-001-523 |
| 011 | 1 | Gasket gearbox cover | 700.561-000 |
| 012 | 4 | Shim | 700.560-xxx |
| 013 | 2 | Cone bearing | P-000-001-502 |
| 014 | 8 | Allen screw | 051.000-08-035-5 |
| 015 | 2 | Bearing cartridge | 700.515-000 |
| 016 | 2 | Cone bearing | P-000-001-503 |
| 017 | 1 | Right hand gear | 700.520-000 |
| 018 | 2 | Key | |
| 019 | 2 | Tab washer | P-000-001-526 |
| 020 | 2 | Lock nut | P-000-001-525 |
| 021 | 1 | Oil retaining ring | P-000-001-522 |
| 022 | 1 | Key | 051.607-06-040-02 |
| 023 | 1 | Drive shaft | 700.513-000 |
| 024 | 1 | Oil sight glass | 054.210-012 |
| 025 | 1 | Oil fill plug with breather | 054.211-011 |
| 026 | 2 | Cylindrical pin | 051.074-050-010-6 |
| 027 | 2 | Plug | 054.108-031-3 |
| 028 | 1 | Gearbox cover | 700.516-000 |
| 029 | 1 | Left hand gear | 700.521-000 |
| 030 | 1 | Lay shaft | 700.514-000 |
| 031 | 4 | Allen screw | 051.000-06-040-5 |
| 032 | 2 | Foot | 700.132-004 |
| 033 | 4 | Allen screw | 051.000-10-025-5 |
| 034 | 1 | Rotor casing | 700.510-000 |
| 035 | 2 | Rotor | 700.511-000 |

User manual Pomac PLP Lobe pump

9.5.3. Part list with article numbers PLP 2

| ITEM. | QUANTITY | DESCRIPTION | ARTICLE NR. | | |
|-------|----------|-----------------------------|-------------------|-------------------|-------------------|
| | | | PLP 2-1,5 | PLP 2-2 | PLP 2-2,5 |
| 001 | 4 | Cap nut | 051.022-12-000-5 | 051.022-12-000-5 | 051.022-12-000-5 |
| 002 | 4 | Stud | 051.073-12-030-5 | 051.073-12-030-5 | 051.073-12-030-5 |
| 003 | 1 | Front cover | 700.217-000 | 700.217-000 | 700.217-000 |
| 004 | 1 | O-Ring | 051.741-100041 | 051.741-100041 | 051.741-100041 |
| 005 | 2 | Rotor retainer | 700.218-000 | 700.218-000 | 700.218-001 |
| 006 | 2 | O-Ring | 051.741-100006 | 051.741-100006 | 051.741-100006 |
| 007 | | **shaft seal** | | | |
| 008 | 2 | Seal cover | 700.250-007 | 700.250-007 | 700.250-007 |
| 009 | 8 | Allen screw | 051.000-05-012-5 | 051.000-05-012-5 | 051.000-05-012-5 |
| 010 | 2 | Oil retaining ring | 051.763-019 | 051.763-019 | 051.763-019 |
| 011 | 1 | Gasket gearbox cover | 700.261-000-A | 700.261-000-A | 700.261-000-A |
| 012 | 4 | Shim | 700.260-000-A | 700.260-000-A | 700.260-000-A |
| 013 | 2 | Cone bearing | 051.658-045-010 | 051.658-045-010 | 051.658-045-010 |
| 014 | 8 | Allen screw | 051.000-10-045-5 | 051.000-10-045-5 | 051.000-10-045-5 |
| 015 | 2 | Bearing cartridge | 700.215-000 | 700.215-000 | 700.215-000 |
| 016 | 2 | Cone bearing | 051.658-035-009 | 051.658-035-009 | 051.658-035-009 |
| 017 | 1 | Right hand gear | 700.220-000 | 700.220-000 | 700.220-000 |
| 018 | 2 | Key | 051.607-10-027-10 | 051.607-10-027-10 | 051.607-10-027-10 |
| 019 | 2 | Tab washer | 051.670-030-000 | 051.670-030-000 | 051.670-030-000 |
| 020 | 2 | Lock nut | 051.669-030-000 | 051.669-030-000 | 051.669-030-000 |
| 021 | 1 | Oil retaining ring | 051.763-018 | 051.763-018 | 051.763-018 |
| 022 | 1 | Key | 051.607-08-040-00 | 051.607-08-040-00 | 051.607-08-040-00 |
| 023 | 1 | Drive shaft | 700.213-001 | 700.213-000 | 700.213-000 |
| 024 | 1 | Oil sight glass | 054.210-012 | 054.210-012 | 054.210-012 |
| 025 | 1 | Oil fill plug with breather | 054.211-011 | 054.211-011 | 054.211-011 |
| 026 | 2 | Cylindrical pin | 051.074-060-010-6 | 051.074-060-010-6 | 051.074-060-010-6 |
| 027 | 2 | Plug | 054.108-032-3 | 054.108-032-3 | 054.108-032-3 |
| 028 | 1 | Gearbox cover | 700.216-000 | 700.216-000 | 700.216-000 |
| 029 | 1 | Left hand gear | 700.221-000 | 700.221-000 | 700.221-000 |
| 030 | 1 | Lay shaft | 700.214-001 | 700.214-000 | 700.214-000 |
| 031 | 4 | Allen screw | 051.000-10-055-5 | 051.000-10-055-5 | 051.000-10-055-5 |
| 032 | 2 | Foot | 700.232-000 | 700.232-000 | 700.232-000 |
| 033 | 4 | Allen screw | 051.000-10-025-5 | 051.000-10-025-5 | 051.000-10-025-5 |
| 034 | 1 | Rotor casing | 700.210-000 | 700.210-000 | 700.210-015 |
| 035 | 2 | Rotor | 700.211-004 | 700.211-000 | 700.211-001 |

User manual Pomac PLP Lobe pump

9.5.4. Part list with article numbers PLP 3

| ITEM. | QUANTITY | DESCRIPTION | ARTICLE NR. | | |
|-------|----------|-----------------------------|-------------------|-------------------|-------------------|
| | | | PLP 3-2 | PLP 3-3 | PLP 3-4 |
| 001 | 4 | Cap nut | 051.022-16-000-5 | 051.022-16-000-5 | 051.022-16-000-5 |
| 002 | 4 | Stud | 051.073-16-045-5 | 051.073-16-045-5 | 051.073-16-045-5 |
| 003 | 1 | Front cover | 700.317-000 | 700.317-000 | 700.317-000 |
| 004 | 1 | O-Ring | 051.741-100042 | 051.741-100042 | 051.741-100042 |
| 005 | 2 | Rotor retainer | 700.318-000-E | 700.318-000-E | 700.318-001-A |
| 006 | 2 | O-Ring | 051.741-100067 | 051.741-100067 | 051.741-100067 |
| 007 | | **shaft seal** | | | |
| 008 | 2 | Seal cover | 700.350-007 | 700.350-007 | 700.350-007 |
| 009 | 12 | Allen screw | 051.000-06-012-5 | 051.000-06-012-5 | 051.000-06-012-5 |
| 010 | 2 | Oil retaining ring | 051.763-025 | 051.763-025 | 051.763-025 |
| 011 | 1 | Gasket gearbox cover | 700.361-000 | 700.361-000 | 700.361-000 |
| 012 | 4 | Shim | 700.360-000 | 700.360-000 | 700.360-000 |
| 013 | 2 | Cone bearing | 051.658-060-012 | 051.658-060-012 | 051.658-060-012 |
| 014 | 8 | Allen screw | 051.000-12-060-5 | 051.000-12-060-5 | 051.000-12-060-5 |
| 015 | 2 | Bearing cartridge | 700.315-000 | 700.315-000 | 700.315-000 |
| 016 | 2 | Cone bearing | 051.658-050-011 | 051.658-050-011 | 051.658-050-011 |
| 017 | 1 | Right hand gear | 700.320-000 | 700.320-000 | 700.320-000 |
| 018 | 2 | Key | 051.607-14-043-10 | 051.607-14-043-10 | 051.607-14-043-10 |
| 019 | 2 | Tab washer | 051.670-045-000 | 051.670-045-000 | 051.670-045-000 |
| 020 | 2 | Lock nut | 051.669-045-000 | 051.669-045-000 | 051.669-045-000 |
| 021 | 1 | Oil retaining ring | 051.763-024 | 051.763-024 | 051.763-024 |
| 022 | 1 | Key | 051.607-12-060-00 | 051.607-12-060-00 | 051.607-12-060-00 |
| 023 | 1 | Drive shaft | 700.313-001 | 700.313-000 | 700.313-000 |
| 024 | 1 | Oil sight glass | 054.210-012 | 054.210-012 | 054.210-012 |
| 025 | 1 | Oil fill plug with breather | 054.211-011 | 054.211-011 | 054.211-011 |
| 026 | 2 | Cylindrical pin | 051.074-080-012-6 | 051.074-080-012-6 | 051.074-080-012-6 |
| 027 | 2 | Plug | 054.108-032-3 | 054.108-032-3 | 054.108-032-3 |
| 028 | 1 | Gearbox cover | 700.316-000 | 700.316-000 | 700.316-000 |
| 029 | 1 | Left hand gear | 700.321-000 | 700.321-000 | 700.321-000 |
| 030 | 1 | Lay shaft | 700.314-001 | 700.314-000 | 700.314-000 |
| 031 | 4 | Allen screw | 051.000-12-080-5 | 051.000-12-080-5 | 051.000-12-080-5 |
| 032 | 2 | Foot | 700.332-000 | 700.332-000 | 700.332-000 |
| 033 | 4 | Allen screw | 051.000-12-030-5 | 051.000-12-030-5 | 051.000-12-030-5 |
| 034 | 1 | Rotor casing | 700.310-014 | 700.310-000 | 700.310-015 |
| 035 | 2 | Rotor | 700.311-004-A | 700.311-000-E | 700.311-001-D |

User manual Pomac PLP Lobe pump

9.5.5. Part list with article numbers PLP 4

| ITEM. | QUANTITY | DESCRIPTION | ARTICLE NR. |
|-------|----------|-----------------------------|-------------------|
| | | | PLP 4-4 |
| 001 | 8 | Cap nut | 051.022-16-000-5 |
| 002 | 8 | Stud | 051.073-16-050-5 |
| 003 | 1 | Front cover | 700.417-000 |
| 004 | 1 | O-Ring | 051.741-100043 |
| 005 | 2 | Rotor retainer | 700.418-000 |
| 006 | 2 | O-Ring | 051.741-100023 |
| 007 | | **shaft seal** | |
| 008 | 2 | Seal cover | 700.450-007 |
| 009 | 12 | Allen screw | 051.000-08-020-5 |
| 010 | 2 | Oil retaining ring | 051.763-031 |
| 011 | 1 | Gasket gearbox cover | 700.461-000 |
| 012 | 4 | Shim | 700.460-000 |
| 013 | 2 | Cone bearing | 051.658-085-014 |
| 014 | 8 | Allen screw | 051.000-16-070-5 |
| 015 | 2 | Bearing cartridge | 700.415-000 |
| 016 | 2 | Cone bearing | 051.658-070-013 |
| 017 | 1 | Right hand gear | 700.420-000 |
| 018 | 2 | Key | 051.607-20-055-10 |
| 019 | 2 | Tab washer | 051.670-065-000 |
| 020 | 2 | Lock nut | 051.669-065-000 |
| 021 | 1 | Oil retaining ring | 051.763-030 |
| 022 | 1 | Key | 051.607-16-090-00 |
| 023 | 1 | Drive shaft | 700.413-000 |
| 024 | 1 | Oil sight glass | 054.210-012 |
| 025 | 1 | Oil fill plug with breather | 054.211-011 |
| 026 | 2 | Cylindrical pin | 051.074-080-018-6 |
| 027 | 2 | Plug | 054.108-032-3 |
| 028 | 1 | Gearbox cover | 700.416-000 |
| 029 | 1 | Left hand gear | 700.421-000 |
| 030 | 1 | Lay shaft | 700.414-000 |
| 031 | 6 | Allen screw | 051.000-16-100-5 |
| 032 | 2 | Foot | 700.432-000 |
| 033 | 4 | Allen screw | 051.000-16-030-5 |
| 034 | 1 | Rotor casing | 700.410-000 |
| 035 | 2 | Rotor | 700.411-000 |

9.6. Materials specification

| Item No. | Description | Materials | Werkstoff Nr. |
|-----------------|--------------------|--------------------|----------------------|
| 3 | Front cover | AISI 316 L | 1.4404 |
| 5 | Rotor retainer | AISI 316 L | 1.4404 |
| 15 | Bearing cartridge | Cast steel | |
| 17 | Right hand gear | 34CrNiMo6 | 1.6582 |
| 29 | Left hand gear | 42CrMo4 | 1.7225 |
| 23 | Drive shaft | X-2 CrNiMoN 22-5-3 | 1.4462 |
| 30 | Lay shaft | | |
| 34 | Rotor case | AISI 316 L | 1.4404 |
| 35 | Rotor | AISI 316 L | 1.4404 |

9.7. Shaft seals

9.7.1. Single mechanical seal , type M1

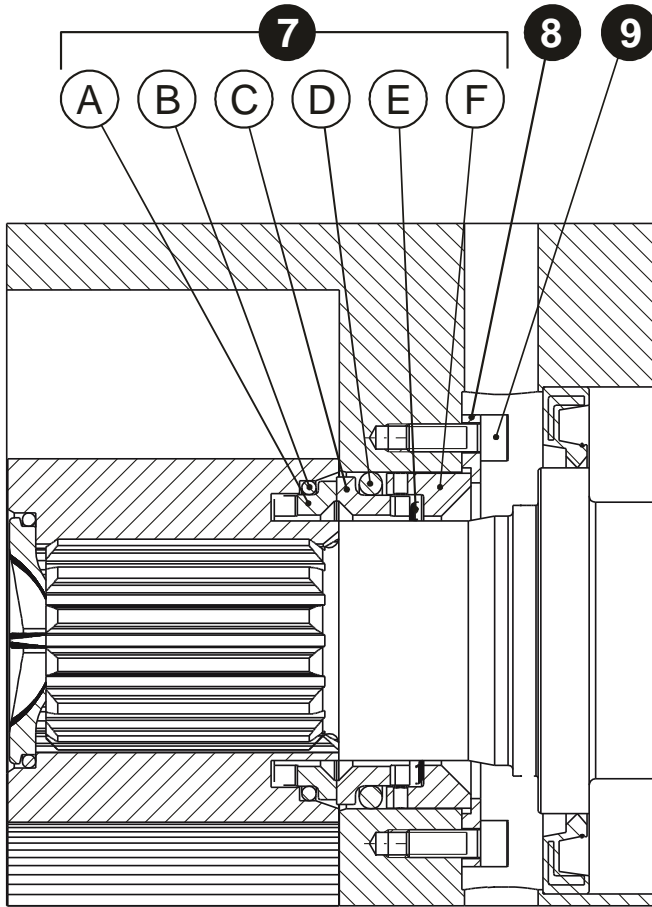

| SINGLE MECHANICAL SEAL M1 (SiC/SiC) | | | Article numbers | | | | |
|-------------------------------------|----------|-------------------------------------|------------------|------------------|------------------|------------------|----------------|
| Item | Quantity | Description | PLP 1/PLP15 | PLP 2 | PLP 3 | PLP 4 | |
| 7A | 1 | ROTARY SEAL RING MEDIUM SIDE | 700.150-001 | 700.250-001 | 700.350-001 | 700.450-001 | |
| 7B | 1 | O-RING | EPDM | 051.741-000005 | 051.741-000011 | 051.741-000021 | 051.741-000030 |
| | | | VITON | 051.760-000005 | 051.760-000011 | 051.760-000021 | 051.760-000030 |
| 7C | 1 | STATIONARY SEAL RING MEDIUM SIDE | 700.150-003 | 700.250-003 | 700.350-003 | 700.450-003 | |
| 7D | 1 | O-RING | EPDM | 051.741-000004 | 051.741-000012 | 051.741-000020 | 051.741-000029 |
| | | | VITON | 051.760-000004 | 051.760-000012 | 051.760-000020 | 051.760-000029 |
| 7E | 1 | WAVE SPRING | 700.150-005 A | 700.250-005 A | 700.350-005 A | 700.450-005 A | |
| 7F | 1 | SEAL SEAT | 700.150-006 A | 700.250-006-A | 700.350-006-A | 700.450-006-A | |
| 8 | 1 | SEAL COVER | 700.150-007 | 700.250-007 | 700.350-007 | 700.450-007 | |
| 9 | 4/6 *) | ALLEN SCREW | 051.000-04-012-5 | 051.000-05-012-5 | 051.000-06-016-5 | 051.000-08-020-5 | |

*) PLP1, PLP15, PLP 2 and PLP 3: quantity 4, PLP 4: quantity 6

9.7.2. Single mechanical seal , type M4

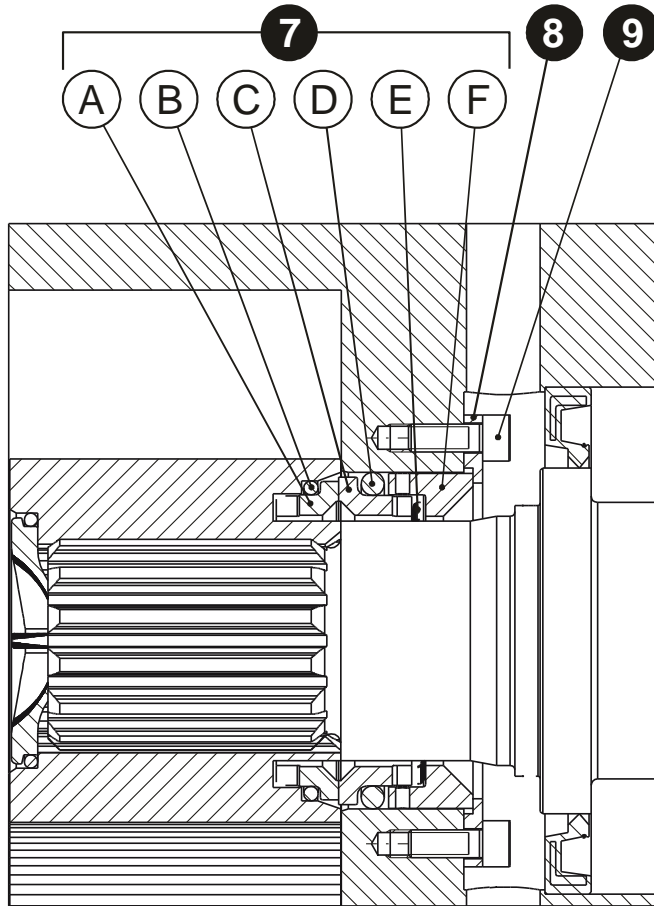

| SINGLE MECHANICAL SEAL M4 (WC/WC) | | | Article numbers | | | | |
|-----------------------------------|----------|-------------------------------------|------------------|------------------|------------------|------------------|----------------|
| Item | Quantity | Description | PLP 1/PLP15 | PLP 2 | PLP 3 | PLP 4 | |
| 7A | 1 | ROTARY SEAL RING MEDIUM SIDE | 700.158-001 | 700.258-001 | 700.358-001 | 700.458-001 | |
| 7B | 1 | O-RING | EPDM | 051.741-000005 | 051.741-000011 | 051.741-000021 | 051.741-000030 |
| | | | VITON | 051.760-000005 | 051.760-000011 | 051.760-000021 | 051.760-000030 |
| 7C | 1 | STATIONARY SEAL RING MEDIUM SIDE | 700.158-002 | 700.258-002 | 700.358-002 | 700.458-002 | |
| 7D | 1 | O-RING | EPDM | 051.741-000004 | 051.741-000012 | 051.741-000020 | 051.741-000029 |
| | | | VITON | 051.760-000004 | 051.760-000012 | 051.760-000020 | 051.760-000029 |
| 7E | 1 | WAVE SPRING | 700.150-005 A | 700.250-005 A | 700.350-005 A | 700.450-005 A | |
| 7F | 1 | SEAL SEAT | 700.150-006 A | 700.250-006-A | 700.350-006-A | 700.450-006-A | |
| 8 | 1 | SEAL COVER | 700.150-007 | 700.250-007 | 700.350-007 | 700.450-007 | |
| 9 | 4/6 *) | ALLEN SCREW | 051.000-04-012-5 | 051.000-05-012-5 | 051.000-06-016-5 | 051.000-08-020-5 | |

*) PLP1, PLP15, PLP 2 and PLP 3: quantity 4, PLP 4: quantity 6

9.7.3. Double mechanical seal, type M2

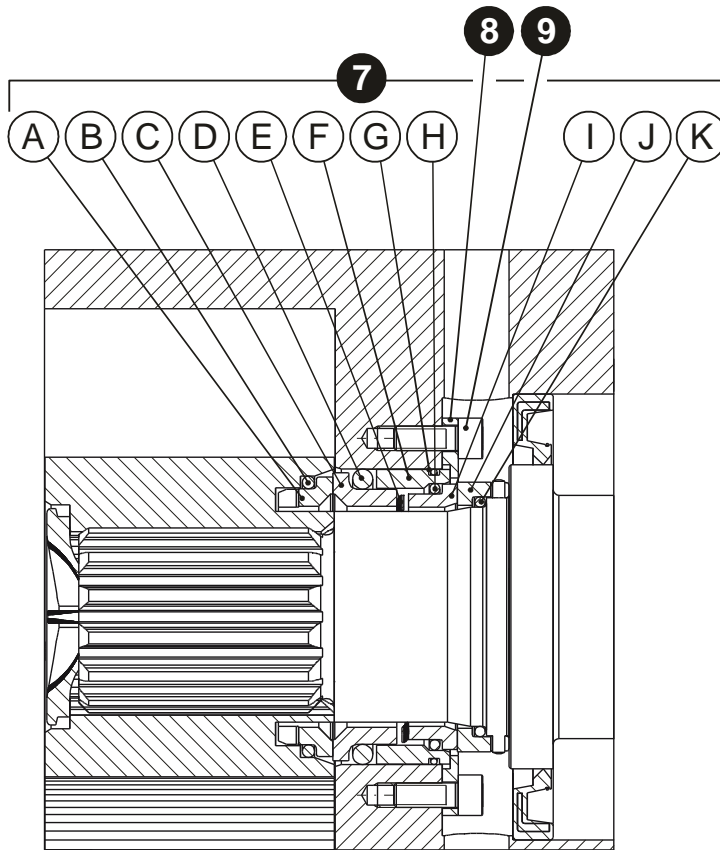

| DOUBLE MECHANICAL SEAL M2 (SiC/SiC – SiC/SiC) | | | Article numbers | | | | |
|--|----------|--|------------------|------------------|------------------|------------------|----------------|
| Item | Quantity | Description | PLP 1/PLP15 | PLP 2 | PLP 3 | PLP 4 | |
| 7A | 1 | ROTARY SEAL RING MEDIUM SIDE | 700.150-001 | 700.250-001 | 700.350-001 | 700.450-001 | |
| 7B | 1 | O-RING | EPDM | 051.741-000005 | 051.741-000011 | 051.741-000021 | 051.741-000030 |
| | | | VITON | 051.760-000005 | 051.760-000011 | 051.760-000021 | 051.760-000030 |
| 7C | 1 | STATIONARY SEAL RING MEDIUM SIDE | 700.150-003 | 700.250-003 | 700.350-003 | 700.450-003 | |
| 7D | 1 | O-RING | EPDM | 051.741-000004 | 051.741-000012 | 051.741-000020 | 051.741-000029 |
| | | | VITON | 051.760-000004 | 051.760-000012 | 051.760-000020 | 051.760-000029 |
| 7E | 1 | WAVE SPRING | 700.150-005 A | 700.250-005 A | 700.350-005 A | 700.450-005 A | |
| 7F | 1 | SEAL SEAT | 700.151-006 C | 700.250-006 A | 700.351-006 A | 700.451-006 A | |
| 7G | 1 | O-RING | EPDM | 051.741-000061 | 051.741-000044 | 051.741-000022 | 051.741-000033 |
| | | | VITON | 051.760-000061 | 051.760-000044 | 051.760-000022 | 051.760-000033 |
| 7H | 1 | O-RING | EPDM | 051.741-000003 | 051.741-000010 | 051.741-000017 | 051.741-000028 |
| | | | VITON | 051.760-000003 | 051.760-000010 | 051.760-000017 | 051.760-000028 |
| 7I | 1 | STATIONARY SEAL RING RING ATM. SIDE | 700.151-011 | 700.251-011 | 700.351-011 | 700.451-011 | |
| 7J | 1 | ROTARY SEAL RING ATM. SIDE | 700.151-012 | 700.251-012 | 700.351-012 | 700.451-012 | |
| 7K | 1 | O-RING | EPDM | 051.741-000001 | 051.741-000008 | 051.741-000015 | 051.741-000024 |
| | | | VITON | 051.760-000001 | 051.760-000008 | 051.760-000015 | 051.760-000024 |
| 8 | 1 | SEAL COVER | 700.150-007 | 700.250-007 | 700.350-007 | 700.450-007 | |
| 9 | 4/6 *) | ALLEN SCREW | 051.000-04-012-5 | 051.000-05-012-5 | 051.000-06-016-5 | 051.000-06-016-5 | |

*) PLP 1, PLP15 and PLP 2: quantity 4, PLP 3 and PLP 4: quantity 6

9.7.4. Double mechanical seal, type M5

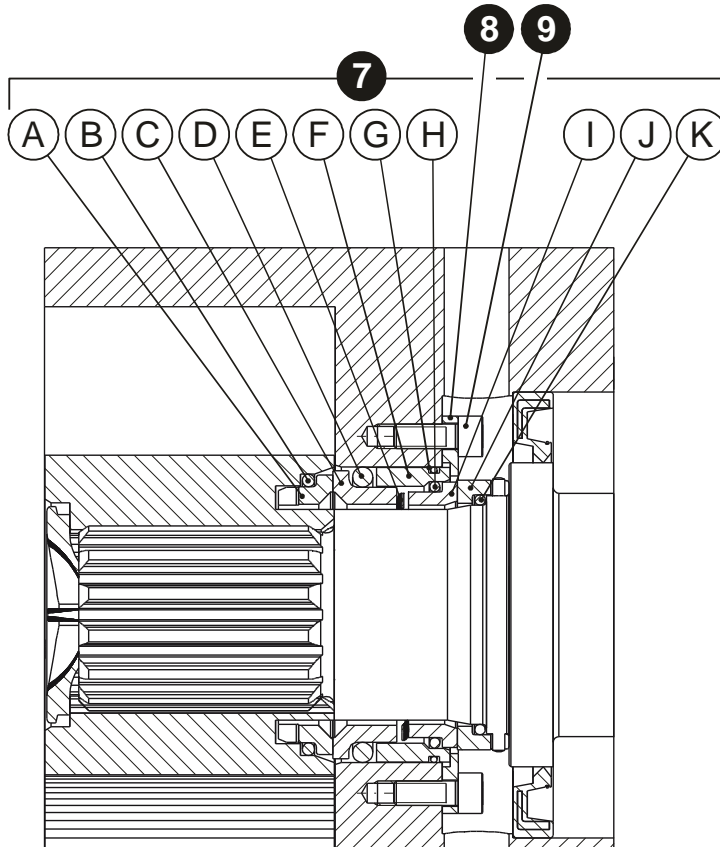

| DOUBLE MECHANICAL SEAL M5 (WC/WC – WC/WC) | | | Article numbers | | | | |
|--|----------|-------------------------------------|------------------|------------------|------------------|------------------|----------------|
| Item | Quantity | Description | PLP 1/PLP15 | PLP 2 | PLP 3 | PLP 4 | |
| 7A | 1 | ROTARY SEAL RING MEDIUM SIDE | 700.158-001 | 700.258-001 | 700.358-001 | 700.458-001 | |
| 7B | 1 | O-RING | EPDM | 051.741-000005 | 051.741-000011 | 051.741-000021 | 051.741-000030 |
| | | | VITON | 051.760-000005 | 051.760-000011 | 051.760-000021 | 051.760-000030 |
| 7C | 1 | STATIONARY SEAL RING MEDIUM SIDE | 700.158-002 | 700.258-002 | 700.358-002 | 700.458-002 | |
| 7D | 1 | O-RING | EPDM | 051.741-000004 | 051.741-000012 | 051.741-000020 | 051.741-000029 |
| | | | VITON | 051.760-000004 | 051.760-000012 | 051.760-000020 | 051.760-000029 |
| 7E | 1 | WAVE SPRING | 700.150-005 A | 700.250-005 A | 700.350-005 A | 700.450-005 A | |
| 7F | 1 | SEAL SEAT | 700.151-006 C | 700.250-006 A | 700.351-006 A | 700.451-006 A | |
| 7G | 1 | O-RING | EPDM | 051.741-000061 | 051.741-000044 | 051.741-000022 | 051.741-000033 |
| | | | VITON | 051.760-000061 | 051.760-000044 | 051.760-000022 | 051.760-000033 |
| 7H | 1 | O-RING | EPDM | 051.741-000003 | 051.741-000010 | 051.741-000017 | 051.741-000028 |
| | | | VITON | 051.760-000003 | 051.760-000010 | 051.760-000017 | 051.760-000028 |
| 7I | 1 | STATIONARY SEAL RING ATM. SIDE | 700.158-003 | 700.258-003 | 700.358-003 | 700.458-003 | |
| 7J | 1 | ROTARY SEAL RING ATM. SIDE | 700.158-004 | 700.258-004 | 700.358-004 | 700.458-003 | |
| 7K | 1 | O-RING | EPDM | 051.741-000001 | 051.741-000008 | 051.741-000015 | 051.741-000024 |
| | | | VITON | 051.760-000001 | 051.760-000008 | 051.760-000015 | 051.760-000024 |
| 8 | 1 | SEAL COVER | 700.150-007 | 700.250-007 | 700.350-007 | 700.450-007 | |
| 9 | 4/6 *) | ALLEN SCREW | 051.000-04-012-5 | 051.000-05-012-5 | 051.000-06-016-5 | 051.000-06-016-5 | |

*) PLP 1, PLP15 and PLP 2: quantity 4, PLP 3 and PLP 4: quantity 6

9.7.5. Single O-ring seal, type O1

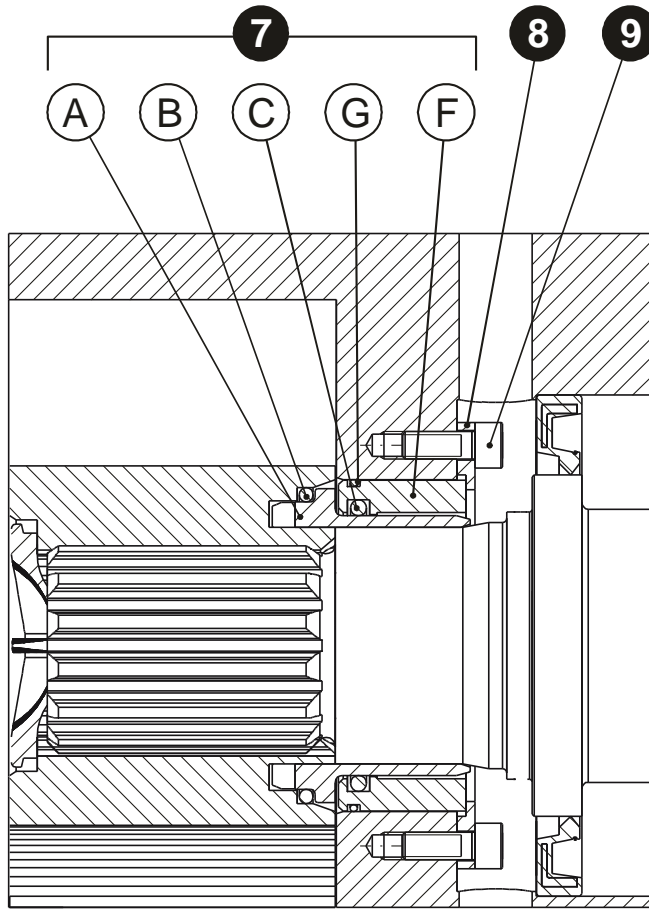

| SINGLE O-RING O1 | | | Article numbers | | | | |
|------------------|----------|--------------|------------------|------------------|------------------|------------------|----------------|
| Item | Quantity | Description | PLP 1/PLP15 | PLP 2 | PLP 3 | PLP 4 | |
| 7A | 1 | SHAFT SLEEVE | 700.152-001 | 700.252-001 | 700.352-001 | 700.452-001 | |
| 7B | 1 | O-RING | EPDM | 051.741-000005 | 051.741-000011 | 051.741-000044 | 051.741-000009 |
| | | | VITON | 051.760-000005 | 051.760-000011 | 051.760-000044 | 051.760-000009 |
| 7C | 1 | O-RING | EPDM | 051.741-000061 | 051.741-000021 | 051.741-000022 | 051.741-000018 |
| | | | VITON | 051.760-000061 | 051.760-000021 | 051.760-000022 | 051.760-000018 |
| 7F | 1 | O-RING | EPDM | 051.741-000002 | 051.741-000030 | 051.741-000033 | 051.741-000027 |
| | | | VITON | 051.760-000002 | 051.760-000030 | 051.760-000033 | 051.760-000027 |
| 7G | 1 | SEAL SEAT | 700.153-005 | 700.253-005 | 700.352-005 | 700.452-005 | |
| 8 | 1 | SEAL COVER | 700.150-007 | 700.250-007 | 700.350-007 | 700.450-007 | |
| 9 | 4/6 *) | ALLEN SCREW | 051.000-04-012-5 | 051.000-05-012-5 | 051.000-06-016-5 | 051.000-08-020-5 | |

*) PLP 1, PLP15 and PLP 2: quantity 4, PLP 3 and PLP 4: quantity 6

9.7.6. Single O-ring seal, type O3

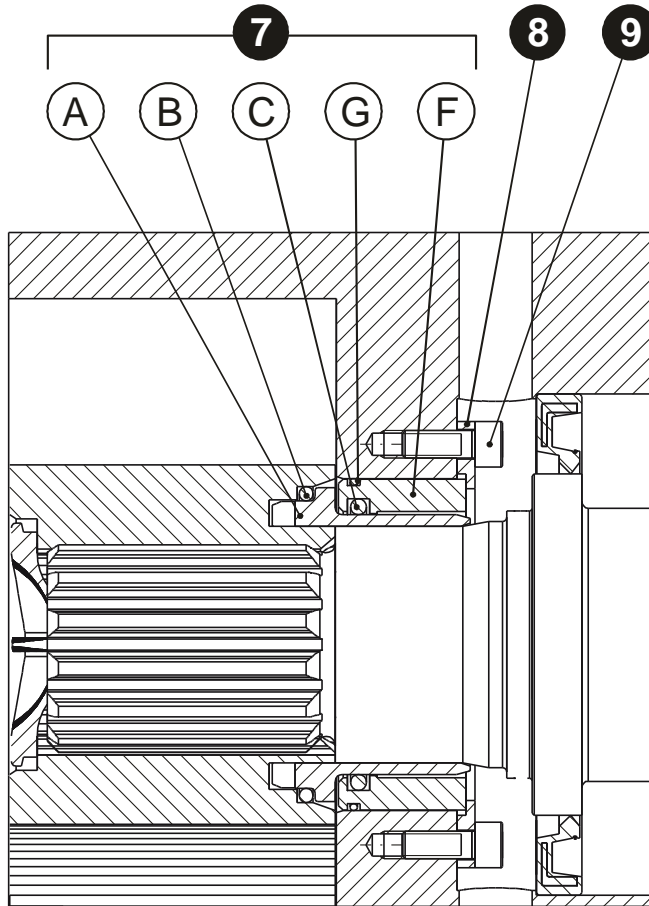

| SINGLE O-RING O3 | | | Article numbers | | | |
|------------------|----------|--------------|----------------------|------------------|------------------|------------------|
| Item | Quantity | Description | PLP 1/PLP15 | PLP 2 | PLP 3 | PLP 4 |
| 7A | 1 | SHAFT SLEEVE | 700.152-201 | 700.252-201 | 700.352-201 | 700.452-201 |
| 7B | 1 | O-RING | EPDM 051.741-000005 | 051.741-000011 | 051.741-000044 | 051.741-000009 |
| | | | VITON 051.760-000005 | 051.760-000011 | 051.760-000044 | 051.760-000009 |
| 7C | 1 | O-RING | EPDM 051.741-000061 | 051.741-000021 | 051.741-000022 | 051.741-000018 |
| | | | VITON 051.760-000061 | 051.760-000021 | 051.760-000022 | 051.760-000018 |
| 7F | 1 | O-RING | EPDM 051.741-000002 | 051.741-000030 | 051.741-000033 | 051.741-000027 |
| | | | VITON 051.760-000002 | 051.760-000030 | 051.760-000033 | 051.760-000027 |
| 7G | 1 | SEAL SEAT | 700.153-005 | 700.253-005 | 700.352-005 | 700.452-005 |
| 8 | 1 | SEAL COVER | 700.150-007 | 700.250-007 | 700.350-007 | 700.450-007 |
| 9 | 4/6 *) | ALLEN SCREW | 051.000-04-012-5 | 051.000-05-012-5 | 051.000-06-016-5 | 051.000-08-020-5 |

*) PLP 1, PLP15 and PLP 2: quantity 4, PLP 3 and PLP 4: quantity 6

9.7.7. Double O-ring seal, type O2

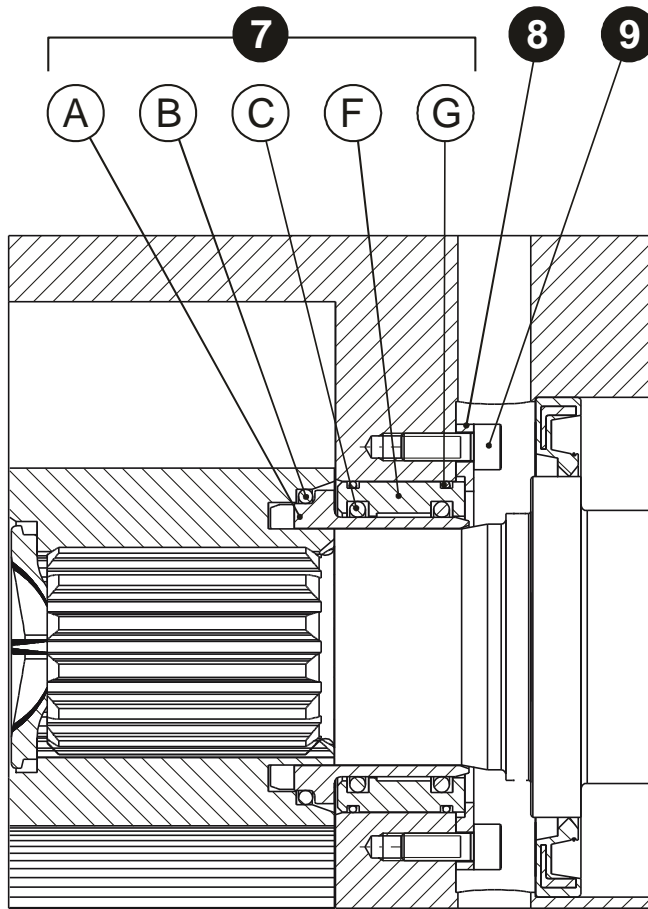

| DOUBLE O-RING O2 | | | Article numbers | | | | |
|------------------|----------|--------------|------------------|------------------|------------------|------------------|----------------|
| Item | Quantity | Description | PLP 1/PLP15 | PLP 2 | PLP 3 | PLP 4 | |
| 7A | 1 | SHAFT SLEEVE | 700.152-001 | 700.252-001 | 700.352-001 | 700.452-001 | |
| 7B | 1 | O-RING | EPDM | 051.741-000005 | 051.741-000011 | 051.741-000044 | 051.741-000009 |
| | | | VITON | 051.760-000005 | 051.760-000011 | 051.760-000044 | 051.760-000009 |
| 7C | 2 | O-RING | EPDM | 051.741-000061 | 051.741-000021 | 051.741-000022 | 051.741-000018 |
| | | | VITON | 051.760-000061 | 051.760-000021 | 051.760-000022 | 051.760-000018 |
| 7F | 2 | O-RING | EPDM | 051.741-000002 | 051.741-000030 | 051.741-000033 | 051.741-000027 |
| | | | VITON | 051.760-000002 | 051.760-000030 | 051.760-000033 | 051.760-000027 |
| 7G | 1 | SEAL SEAT | 700.153-005 | 700.253-005 | 700.352-005 | 700.452-005 | |
| 8 | 1 | SEAL COVER | 700.150-007 | 700.250-007 | 700.350-007 | 700.450-007 | |
| 9 | 4/6 *) | ALLEN SCREW | 051.000-04-012-5 | 051.000-05-012-5 | 051.000-06-016-5 | 051.000-08-020-5 | |

*) PLP 1, PLP15 and PLP 2: quantity 4, PLP 3 and PLP 4: quantity 6

9.7.8. Double O-ring seal, type O4

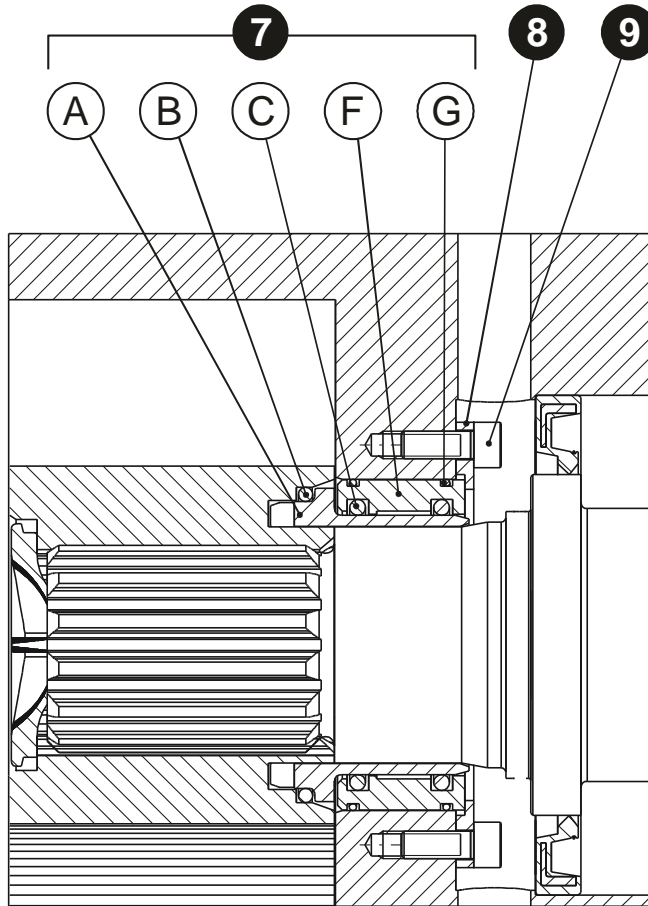

| DOUBLE O-RING O4 | | | Article numbers | | | | |
|------------------|----------|--------------|------------------|------------------|------------------|------------------|----------------|
| Item | Quantity | Description | PLP 1/PLP15 | PLP 2 | PLP 3 | PLP 4 | |
| 7A | 1 | SHAFT SLEEVE | 700.152-201 | 700.252-201 | 700.352-201 | 700.452-201 | |
| 7B | 1 | O-RING | EPDM | 051.741-000005 | 051.741-000011 | 051.741-000044 | 051.741-000009 |
| | | | VITON | 051.760-000005 | 051.760-000011 | 051.760-000044 | 051.760-000009 |
| 7C | 2 | O-RING | EPDM | 051.741-000061 | 051.741-000021 | 051.741-000022 | 051.741-000018 |
| | | | VITON | 051.760-000061 | 051.760-000021 | 051.760-000022 | 051.760-000018 |
| 7F | 2 | O-RING | EPDM | 051.741-000002 | 051.741-000030 | 051.741-000033 | 051.741-000027 |
| | | | VITON | 051.760-000002 | 051.760-000030 | 051.760-000033 | 051.760-000027 |
| 7G | 1 | SEAL SEAT | 700.153-005 | 700.253-005 | 700.352-005 | 700.452-005 | |
| 8 | 1 | SEAL COVER | 700.150-007 | 700.250-007 | 700.350-007 | 700.450-007 | |
| 9 | 4/6 *) | ALLEN SCREW | 051.000-04-012-5 | 051.000-05-012-5 | 051.000-06-016-5 | 051.000-08-020-5 | |

*) PLP 1, PLP15 and PLP 2: quantity 4, PLP 3 and PLP 4: quantity 6

9.7.9. Lip seal, type L1

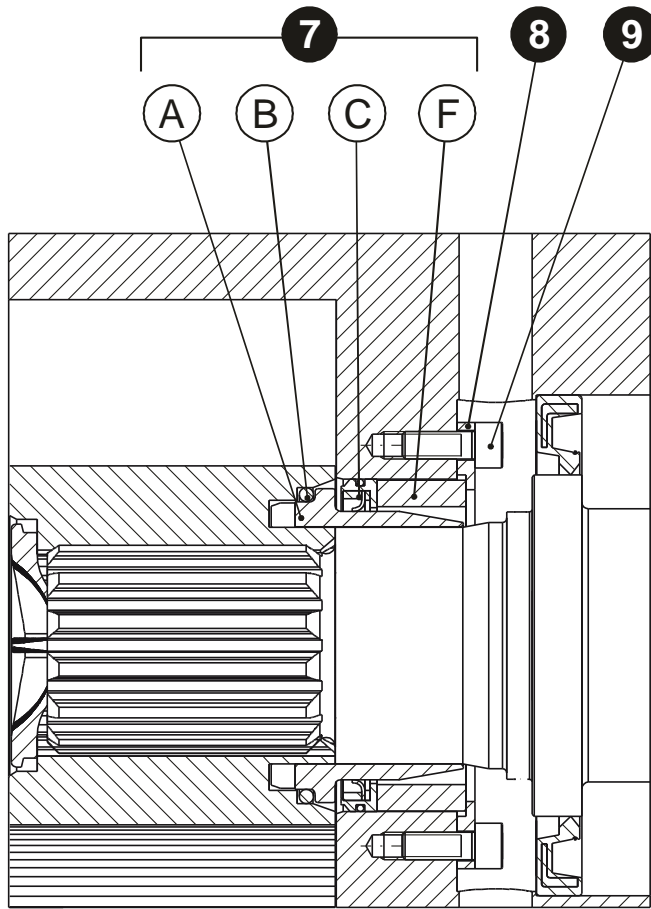

| LIP SEAL L1 | | | Article numbers | | | |
|-------------|----------|--------------|------------------|------------------|------------------|----------------|
| Item | Quantity | Description | PLP 1/PLP15 | PLP 2 | PLP 3 | |
| 7A | 1 | SHAFT SLEEVE | 700.154-201 | 700.254-201 | 700.354-201 | |
| 7B | 1 | O-RING | EPDM | 051.741-000005 | 051.741-000011 | 051.741-000021 |
| | | | VITON | 051.760-000005 | 051.760-000011 | 051.760-000021 |
| 7C | 1 | MC-LIP SEAL | 051.764-001 | 051.764-002 | 051.764-003 | |
| 7F | 1 | SEAL SEAT | 700.154-005 | 700.254-005 | 700.354-004 | |
| 8 | 1 | SEAL COVER | 700.150-007 | 700.250-007 | 700.350-007 | |
| 9 | 4/6 *) | ALLEN SCREW | 051.000-04-012-5 | 051.000-05-012-5 | 051.000-06-016-5 | |

*) PLP 1, PLP15 and PLP 2: quantity 4, PLP 3: quantity 6

9.7.10. Lip seal, type L2

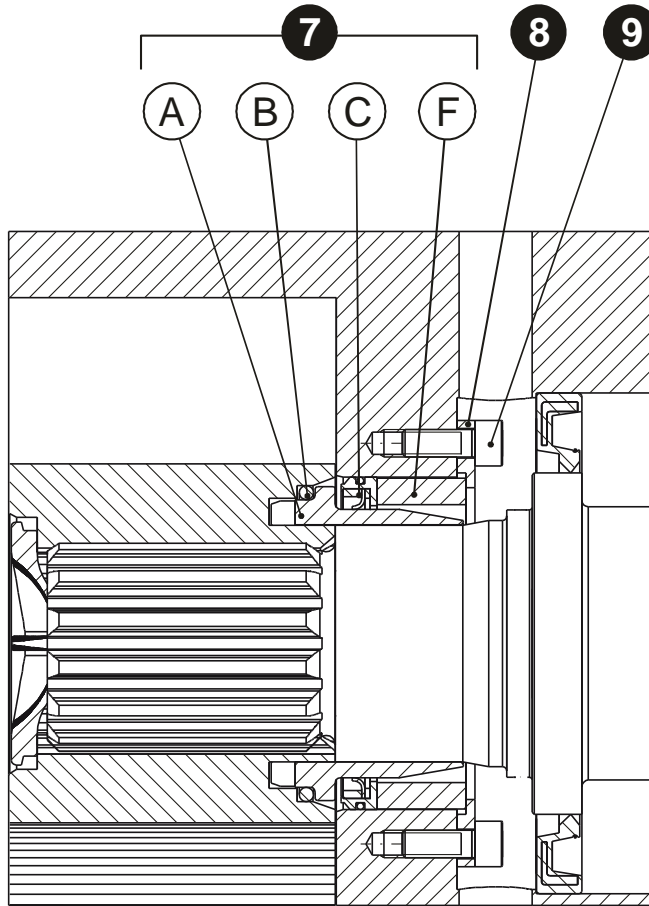

| LIP SEAL L2 | | | Article numbers | | | |
|-------------|----------|--------------|------------------|------------------|------------------|----------------|
| Item | Quantity | Description | PLP 1/PLP15 | PLP 2 | PLP 3 | |
| 7A | 1 | SHAFT SLEEVE | 700.154-101 | 700.254-101 | 700.354-101 | |
| 7B | 1 | O-RING | EPDM | 051.741-000005 | 051.741-000011 | 051.741-000021 |
| | | | VITON | 051.760-000005 | 051.760-000011 | 051.760-000021 |
| 7C | 1 | MC-LIP SEAL | 051.764-001 | 051.764-002 | 051.764-003 | |
| 7F | 1 | SEAL SEAT | 700.154-005 | 700.254-005 | 700.354-004 | |
| 8 | 1 | SEAL COVER | 700.150-007 | 700.250-007 | 700.350-007 | |
| 9 | 4/6 *) | ALLEN SCREW | 051.000-04-012-5 | 051.000-05-012-5 | 051.000-06-016-5 | |

*) PLP 1, PLP15 and PLP 2: quantity 4, PLP 3: quantity 6

9.7.11. Lip seal, type L3

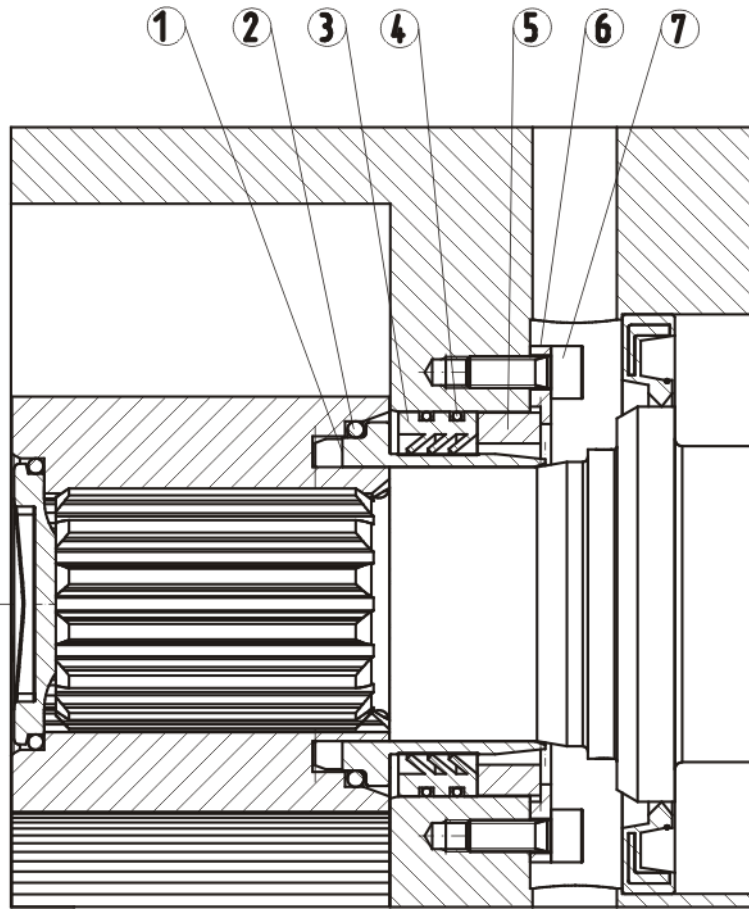

| LIP SEAL L3 | | | Article numbers | | |
|-------------|----------|--------------|------------------|------------------|------------------|
| Item | Quantity | Item | Quantity | Item | Quantity |
| 1 | 1 | SHAFT SLEEVE | 700.154-201 | 700.254-201 | 700.354-201 |
| 2 | 1 | O-RING | | | |
| 3 | 1 | WDR LIP SEAL | 700.154-006 | 700.254-006 | 700.354-006 |
| 4 | 1 | O-RING | | | |
| 5 | 1 | SEAL SEAT | 700.154-005 | 700.254-005 | 700.354-004 |
| 6 | 1 | SEAL COVER | 700.150-007 | 700.250-007 | 700.350-007 |
| 7 | 4/6 *) | ALLEN SCREW | 051.000-04-012-5 | 051.000-05-012-5 | 051.000-06-016-5 |

*) PLP 1, PLP 15 and PLP 2: quantity 4, PLP 3: quantity 6

9.8. Spring loaded safety valve

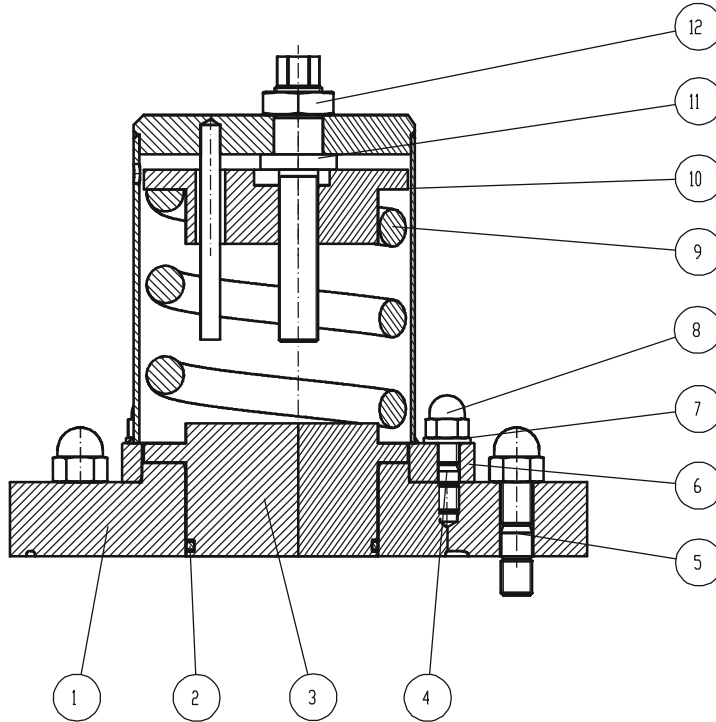

| Item | Quantity | Description | Article numbers | | | | |
|------|----------|--------------------|-------------------|-------------------|-------------------|-------------------|----------------|
| | | | PLP 1 | PLP 2 | PLP 3 | PLP 15 | |
| 1 | 1 | PUMP COVER | 700.117-002 | 700.217-002 | 700.317-002 | 700.517-004 | |
| 2 | 1 | O- RING | EPDM | 051.741.000013 | 051.741.000025 | 051.741.000035 | 051.741.000013 |
| | | | VITON | 051.760.000013 | 051.760.000025 | 051.760.000035 | 051.760.000013 |
| 3 | 1 | PLUNGER | 700.109-001 | 700.209-001 | 700.309-001 | 700.109-001 | |
| 4 | 4 | STUD | 051.073-063-020-5 | 051.073-063-030-5 | 051.073-063-035-5 | 051.073-063-020-5 | |
| 5 | 4 | STUD | 051.073-08-025 | 051.073-12-045-5 | 051.073-12-055-5 | 051.073-08-025 | |
| 6 | 1 | CASING | 700.109-002 | 700.209-002 | 700.309-002 | 700.109-002 | |
| 7 | 4 | WASHER | 051.013-06-000-5 | 051.013-10-000-5 | 051.013-12-000-5 | 051.013-06-000-5 | |
| 8 | 4 | CAP NUT | 051.022-06-000-5 | 051.022-10-000-5 | 051.022-12-000-5 | 051.022-06-000-5 | |
| 9 | 1 | PRESSURE SPRING | 700.109-005 | 700.209-005 | 700.309-005 | 700.109-005 | |
| 10 | 1 | PRESSURE DISK | 700.109-003 | 700.209-003 | 700.309-003 | 700.109-003 | |
| 11 | 1 | SET SCREW | 700.109-004 | 700.209-004 | 700.309-004 | 700.109-004 | |
| 12 | 1 | LOCKNUT | 051.080.000002 | 051.080.000003 | 051.080.000004 | 051.080.000002 | |

9.9. Air loaded safety valve

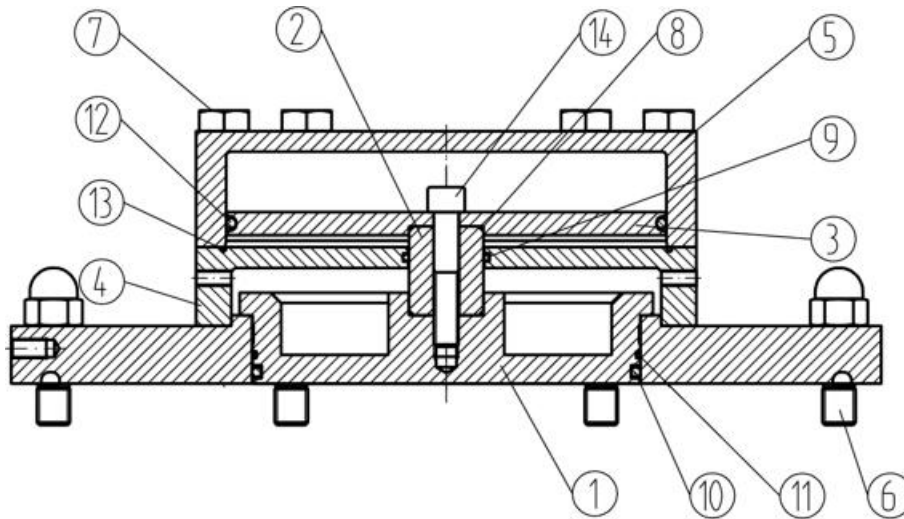

| ITEM. | QUANTITY | DESCRIPTION | ARTICLE NR. |
|-------|----------|--|-------------------|
| | | | PLP 4 |
| 001 | 1 | Plunger for air-loaded safety valve PLP 4 | 700.409-101 |
| 002 | 1 | Spacer bush | 700.409-102 |
| 003 | 1 | Piston | 700.409-103 |
| 004 | 1 | Intermediate ring | 700.409-104 |
| 005 | 1 | Casing for air-loaded safety valve PLP 4 | 700.409-105 |
| 006 | 8 | Stud M16x45 A2 | 051.073.-16-045-5 |
| 007 | 8 | Hexagon bolt M16x110 A2 | 051.001.-16-110-5 |
| 008 | 2 | O-ring 33,05x1,78 NBR 70°S | P-000-002-095 |
| 009 | 1 | O-ring 36,09x3,53 NBR 70°S | P-000-002-090 |
| 010 | 1 | O-ring 177,17x5,33 Viton 80°S | P-000-002-105 |
| 011 | 1 | O-ring 177,47x2,62 Viton 80°S | P-000-002-097 |
| 012 | 1 | O-ring 202,57x5,33 Viton 80°S | P-000-002-092 |
| 013 | 0,7 | O-ring string D 2,40 NBR | P-000-002-095 |
| 014 | 1 | Allen screw M12x65 A2 | 051.000.-12-065-5 |
| 015 | 1 | Pump cover for air-loaded safety valve PLP 4 | 700.417-007 |

10. Trouble shooting

A malfunction in a pump system may have various causes. The malfunction is not always necessarily in the pump itself, but can also be caused by a malfunction in the piping system, or in another appendage in the system. If the operating conditions differ too greatly from the specifications by which the pump was purchased this can also cause malfunctioning.

Therefore always check first:

- Has the pump been installed correctly?
- Are the operating conditions still according to the initial specifications?
- Are the other appendages in the pipe system functioning correctly?
-

In general terms, the following malfunctions in a pump can be distinguished:

1. pump gives no liquid
2. pump gives irregular liquid flow
3. capacity too low
4. pump overheats
5. motor overheats
6. excessive rotor wear
7. excessive wear of shaft sealing
8. pump vibrates excessively or makes too much noise
9. pump stops
10. pump comes to a stop at start-up

The table on the next page gives a possible cause and solution for the malfunctions mentioned above.

| Fault | | | | | | | | | | Cause | Action | |
|-------|---|---|---|---|---|---|---|---|----|-------|---------------------------------------|---|
| 1 | 2 | 3 | 4 | 5 | 6 | 7 | 8 | 9 | 10 | | | |
| * | | | | | | | | | | | wrong direction of rotation | reverse direction of rotation of drive |
| * | | | | | | | | | | | pump is not filled with liquid | vent suction line and rotor case and prime rotor case with liquid |
| * | * | * | | | | | | * | | | insufficient NPSHA | Enlarge diameter of suction line, or simplify suction line and make it shorter, or reduce speed and product temperature |
| | | * | * | | | | | | * | | creation of vapour in suction line | |
| | * | * | | | | | | * | | | air entering the suction line | check the connections |
| * | * | * | | | | | | * | | | gas in the suction line | vent suction line/pump casing |
| | * | * | | | | | | * | | | insufficient static head | increase liquid level to enlarge static head |
| | | | * | * | | | | * | | * | product viscosity is too high | lower the speed / increase the product temperature |
| | | * | | | | | | | | | product viscosity is too low | increase the speed / lower the product temperature |
| | | * | * | | * | | | * | | * | product temperature is too high | cool the product/pump casing |
| | | | | * | | | | | | * | product temperature is too low | heat the product/rotor case |
| | | | | | * | * | * | * | | | foreign particles in the product | clean the system/ place a filter at suction side |
| | | * | * | * | * | | | * | * | * | pressure at delivery side is too high | check piping for obstructions / simplify the pressure line |
| | | | * | * | * | | | * | * | | rotor case distorted by piping | check alignment / support the piping |
| | | | | * | | | | * | | | speed too high | lower the speed |
| | | * | | | | | | | | | speed too low | increase the speed |
| | | | * | * | * | * | * | * | | | insufficient flushing | increase flushing pressure / - capacity |
| | | | * | * | * | * | * | * | * | | worn-out bearings/gears | replace the worn-out parts |
| * | | | | | | | | | | | safety valve is opened | Check if delivery valve is opened/check piping for obstructions/check piping system for pressure loss |

Index

- Adjusting the clearance, 30
- Alignment tolerances, 17
- Allen screw, 27, 30, 34
- Application area, 10
- bearing cartridge, 10, 27, 28, 30, 31
- brass sheet, 34
- Built-in dimensions, 14
- cap nut, 18, 19, 25, 34
- Changed application, 6
- Checking, 21
- circulating, 22
- clearance, 30, 31
- Closing down, 36
- Connecting the drive, 20
- Construction, 11
- Coupling alignment, 16
- Delivery program, 10
- differential pressure, 12
- Dimensions, 38
- Disassembly, 24
- Dismantling, 25, 36
- Dismantling the pump, 25
- Disposal, 36
- Double mechanical seal, 10, 32, 47, 48
- Double mechanical seal assembly, 32
- Double O-ring, 10, 51, 52
- Draining the pump, 25
- drive shaft, 16, 20, 27, 28
- feeler gauge, 34
- Filling, 35
- Fitting additional connections, 17
- flush, 18, 21, 22
- Flushing the system, 18
- foot, 15
- Foundation, 14
- front cover, 18, 19, 20, 24, 25, 34
- gasket, 27, 34
- Gearbox assembly, 27
- gearbox cover, 27, 34
- General information, 5, 6, 7, 13
- General survey, 23
- heating jacket, 9, 18, 22, 24, 25
- Hoisting, 13
- In operation, 22
- Installation, 13
- Introduction, 5
- key, 25, 27, 28
- lay shaft, 28
- Lip seal, 10, 33, 53, 54
- Lip seal assembly, 33
- liquid temperature, 22
- lock nut, 27, 29
- Maintenance, 23
- Manufacturer, 5
- mechanical seal, 8, 10, 26, 32, 45, 46, 47, 48
- Oil, 20, 23, 25, 37
- Oil change, 23
- Oil draining, 25
- oil fill plug, 20, 34, 35
- Oil filling, 20
- oil quantities, 37
- oil sight glass, 20, 21, 34, 35
- oil types, 37
- Operating principle, 10
- Operation, 21
- Ordering spare parts, 24
- O-ring, 10, 18, 19, 25, 32, 33, 34, 49, 50, 51, 52
- O-ring seal assembly, 32
- pallet, 13
- Parts inspection, 27
- parts list, 24, 25, 27, 39
- Piping, 15
- Pump disassembly, 25
- Pump-unit assembly, 16
- quattro lobes, 28, 33
- quench, 21, 25
- rotor, 18, 19, 24, 30, 32, 33, 56
- rotor retainer, 18, 19, 33
- rotorcase, 14, 17, 18, 19, 25, 26, 27, 29, 30, 32, 33, 34, 36, 57
- Rotorcase assembly, 34
- Safety, 6, 9, 14, 24
- Safety measures, 24
- safety relief valve, 9, 25
- safety valve, 12, 27, 35
- safety valve, 22
- seal cover, 27, 29, 32, 33
- Sectional drawing, 39
- setscrew, 12
- shaft seal, 10, 17, 18, 21, 22, 25, 26, 27, 56
- Shaft seals, 10, 45
- shim, 30, 31
- Shutting down, 22
- Single mechanical seal, 10, 32, 45, 46
- Single mechanical seal assembly, 32
- Single O-ring, 49, 50
- Special tools, 24
- spring-loaded, 12, 35
- Staff, 6
- Start Up, 21
- Storage, 36
- system conditions, 22
- tab washer, 27, 29
- Technical data, 37
- Transport, 5, 13
- Trouble shooting, 56
- type, 17, 18, 21, 24, 28, 29, 30, 31, 32, 33, 45, 46, 49, 50, 51, 52, 53, 54
- Type code PLP, 7
- Warranty, 5