

# CP-AGF-*line*

**Stainless steel pumps with channel impeller**  
for fruit, vegetable and potato processing industry



**Pomac Pumps**

## Stainless steel centrifugal pumps

The **Pomac CP-AGF** programme comprises a range of stainless steel pumps, suited for pumping potatoes, vegetables and fruits, without damaging them.

The pumps can be supplied with a single channel or a dual channel impeller. The impeller hub is mounted directly to the motor shaft, which results in a minimal overhang and a short build. The impeller can easily be removed without dismantling the pump casing.

The pump casing is fitted with inspection covers, allowing inspection of the pump interior without the pump needing to be removed and dismantled.

The pumps are available in 4 build sizes:

500 (NW 100)

750 (NW 150)

1000 (NW 200)

1250 (NW 250)

Max. solids passage [mm]:

500: 100

750: 150

1000: 200

1250: 250

## Construction

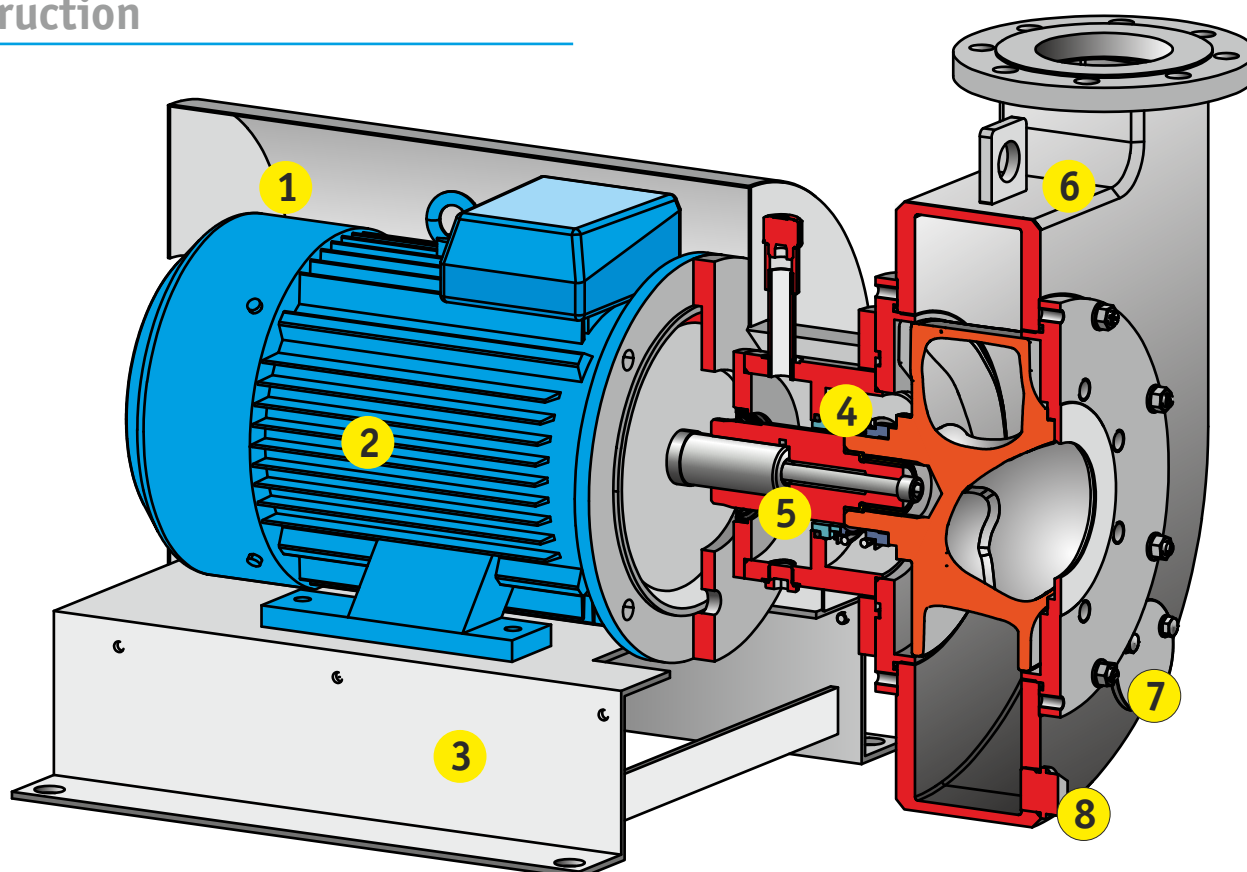

1. Stainless steel motor shroud supplied as standard
2. Standard IEC foot/flange motor
3. Close-coupled set-up on stainless steel base
4. Internal mechanical seal (SiC/SiC EPDM), fitted with oil bath quench
5. Impeller hub mounted directly to the motor shaft
6. Pump casing position can rotate 45 degrees or according to client specs.
7. Pump casing fitted with inspection covers
8. Pump casing fitted with drain

# Curves

CP-AGF 500-100

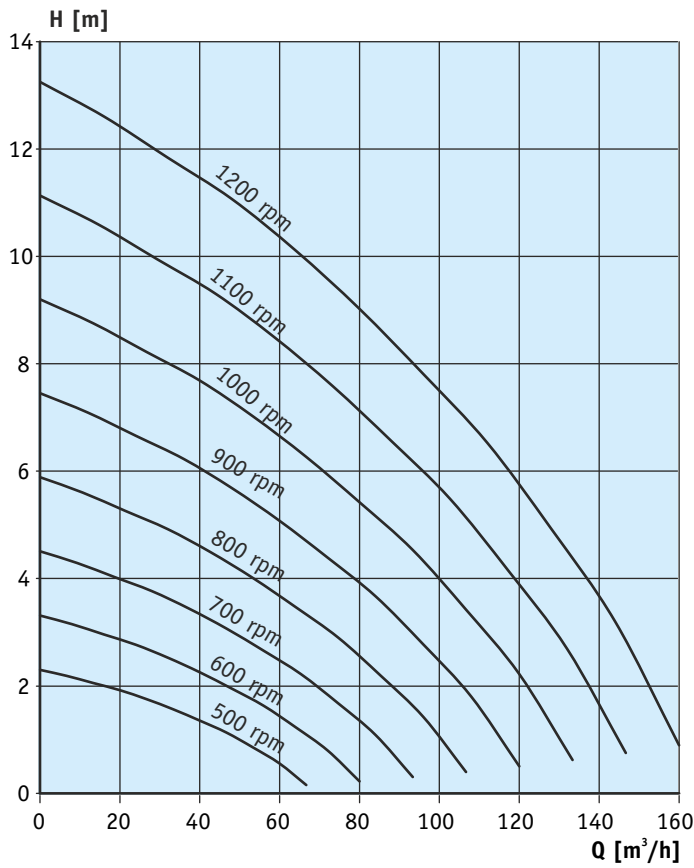

CP-AGF 750-150

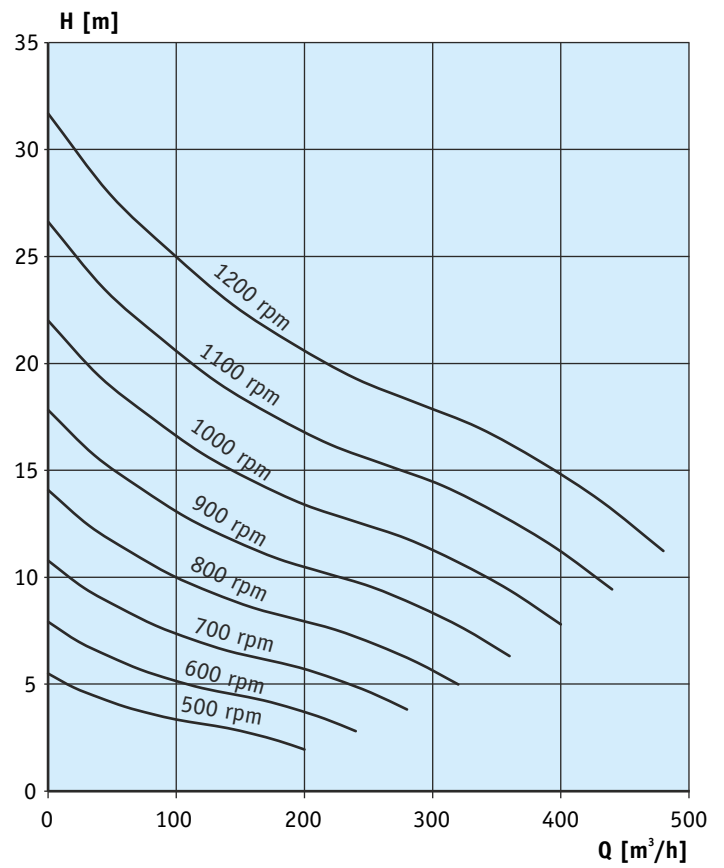

CP-AGF 1000-200

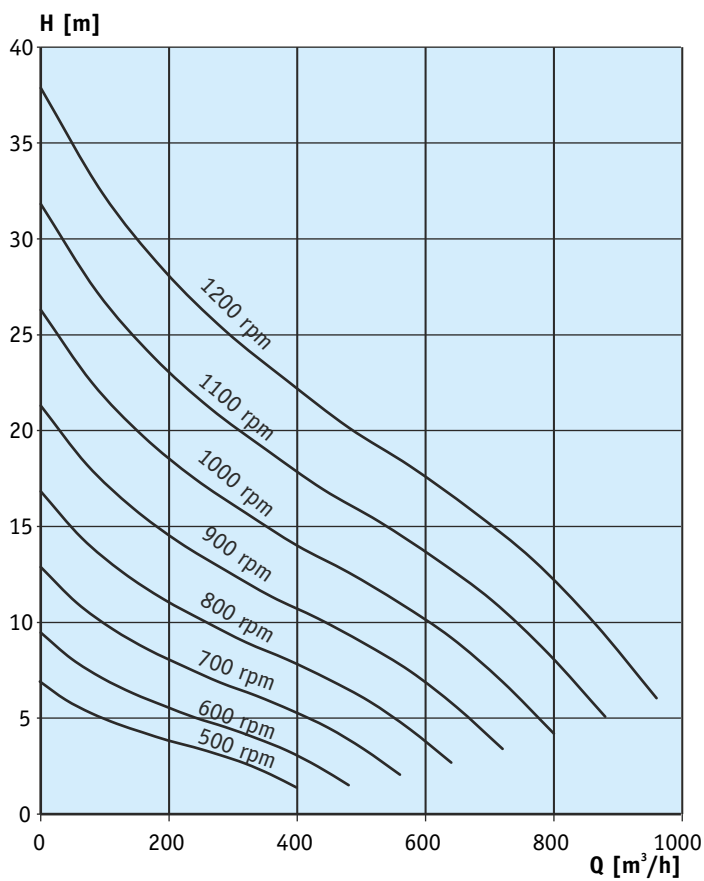

CP-AGF 1250-550

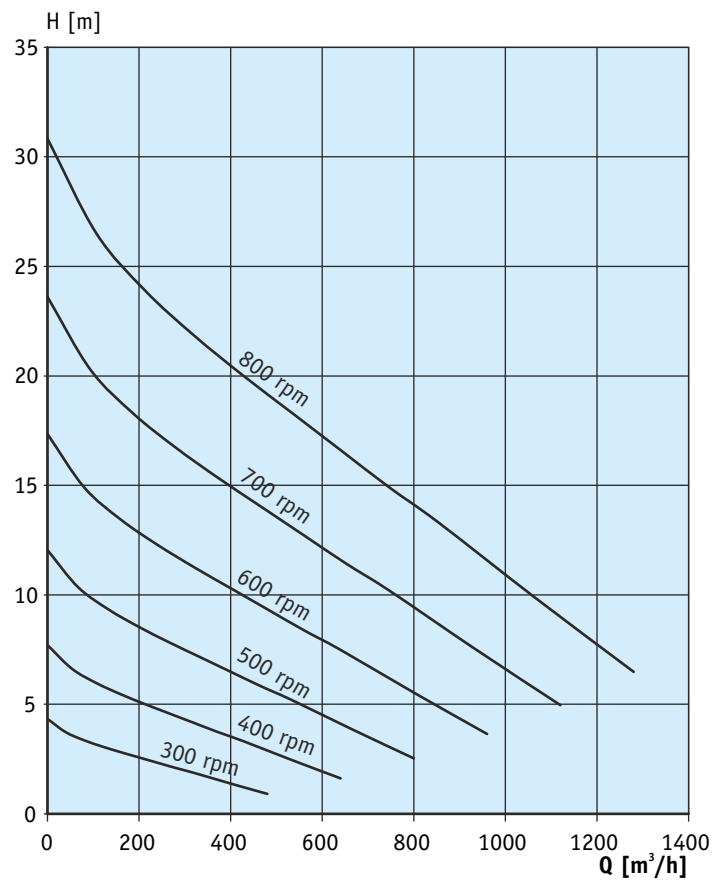

Dimensions

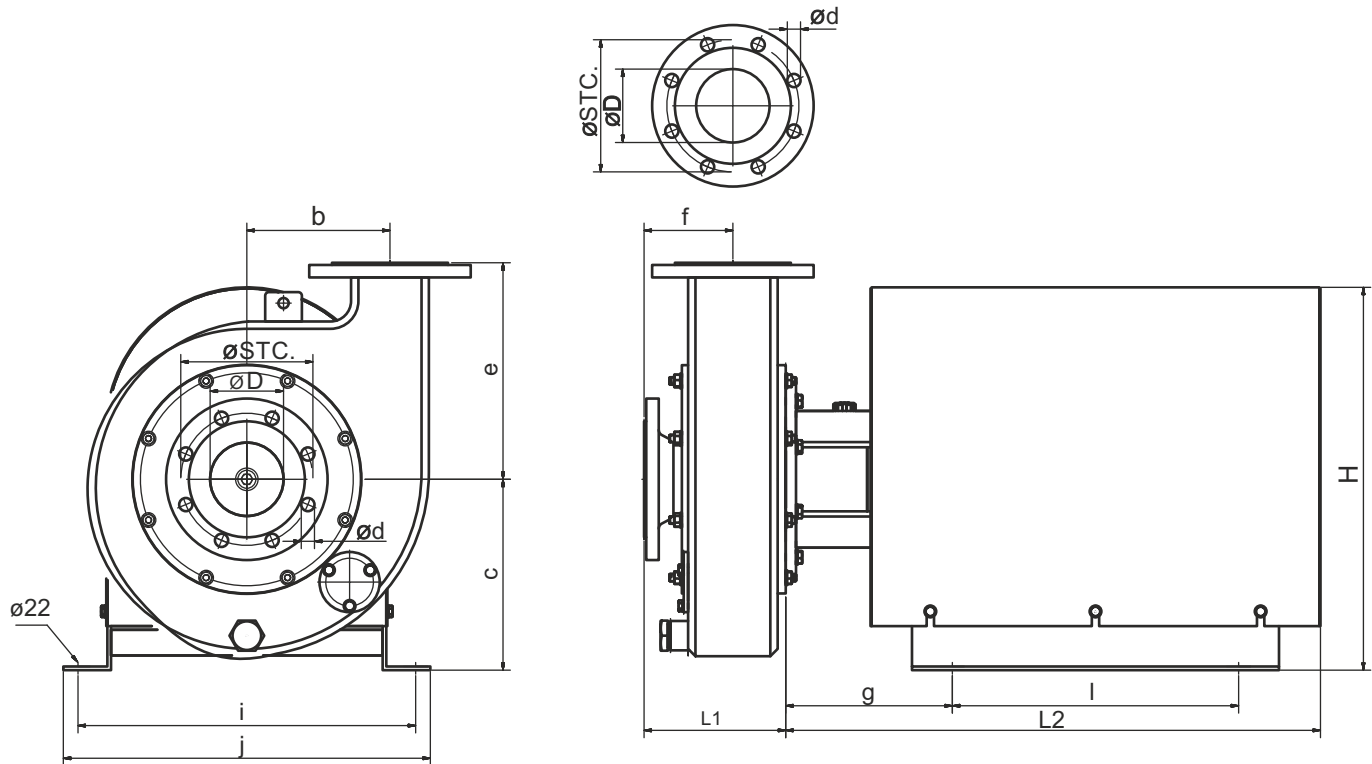

SIZE	RPM	P(kW)	IEC	b	d	D	M	e	f	STC	L1	c	g	H	i	j	l	L2
50044	1000	5,5	132	195	18	100	16	295	78	180	157	260	132	470	430	470	440	599
50044	1000	7,5	132	195	18	100	16	295	78	180	157	260	227	521	460	500	390	729
50044	1500	5,5	132	195	18	100	16	295	78	180	157	260	132	470	430	470	440	599
50044	1500	7,5	160	195	18	100	16	295	78	180	157	260	132	470	430	470	440	599
75066	1000	11	160	330	22	150	20	500	115	240	215	410	200	726	490	530	540	820
75066	1000	15	180	330	22	150	20	500	115	240	215	410	200	726	490	530	540	820
75066	1000	18,5	200	330	22	150	20	500	115	240	215	410	200	765	546	584	540	965
75066	1000	22	200	330	22	150	20	500	115	240	215	410	200	765	546	584	540	965
100088	1000	22	200	395	22	200	20	560	140	360	263	480	200	835	546	584	540	965
100088	1000	30	225	395	22	200	20	560	140	360	263	480	200	856	586	626	540	1040
125010	750	37	280	540	26	250	24	689	176	355	334	630	200	1118	710	760	799	1241
125010	750	45	280	540	26	250	24	689	176	355	334	630	200	1118	710	760	799	1241



**Pomac Pumps**

**Pomac b.v**  
 Feithspark 13 - 9356 BX Tolbert  
 P.O. Box 32 - 9356 ZG Tolbert  
 The Netherlands  
 tel +31 (0)594 512877  
 fax +31 (0)594 517002  
 E-mail: info@pomacpumps.com  
 www.pomacpumps.com