

SP-LR-*line*

Self-priming liquid ring pumps
for hygienic process applications, according to EHEDG

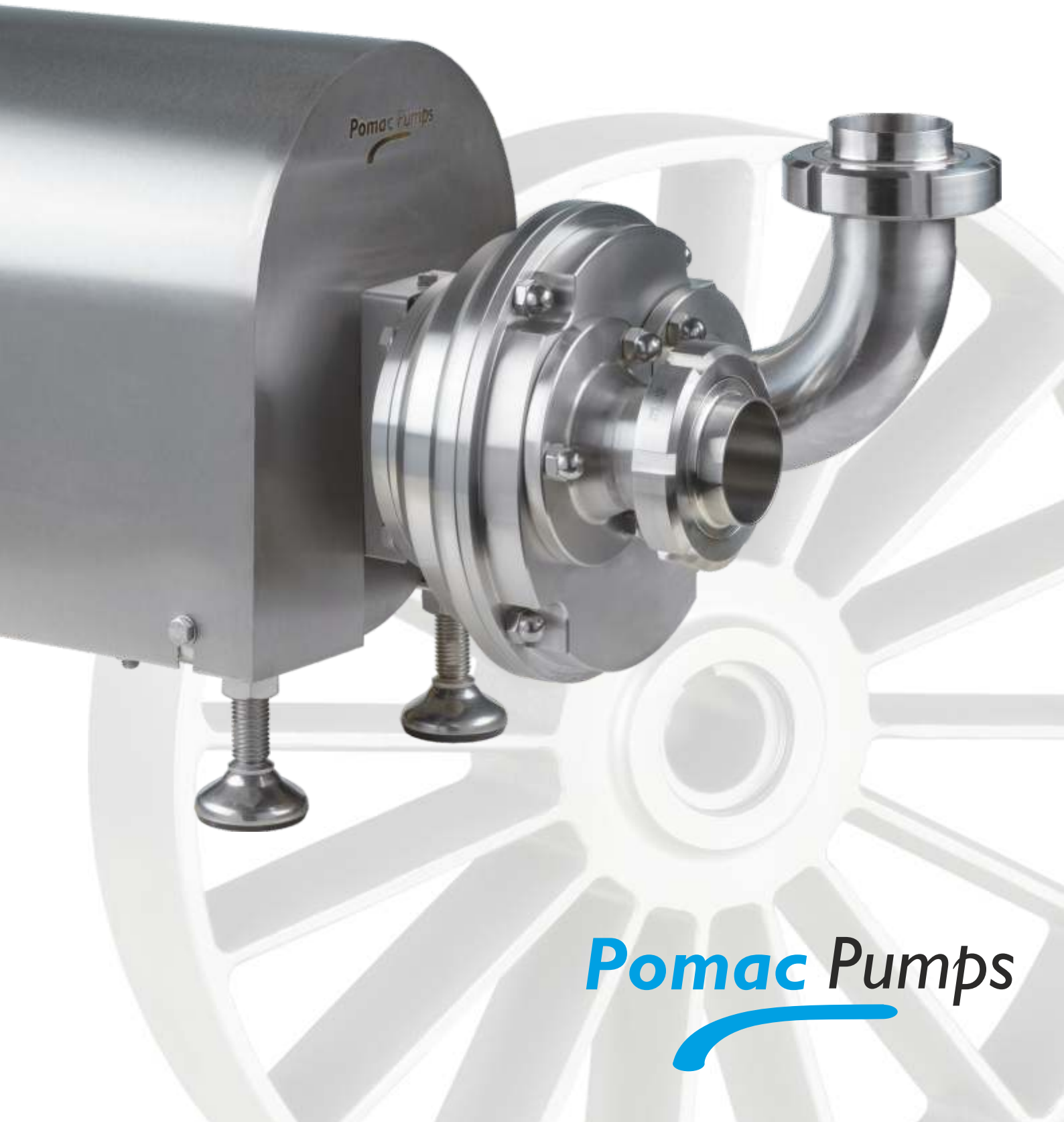

Pomac Pumps

Self Priming Liquid Ring Pumps

The self priming liquid ring pumps SP-LR are special designed for pumping liquid that contains air or gas. This type of liquids are CIP return applications in the food-, dairy-, beverage- and pharmaceutical industry.

Ultra clean

All liquid contact parts of the SP-LR pumps are compliant with the relevant standards.

The open impeller ensures an optimal cleaning of the shaft and seal chamber. The impeller is dry mounted. The applied "O"-ring constructions are designed to minimize the liquid contact and at the same time to provide an optimal cleaning of the contact faces

Materials

All parts that come into contact with the pumped liquid are made of stainless steel, Materials nr. 1.4404. At request these parts can also be made of Materials nr. 1.4435 or Materials nr. 2.4602 (Hastelloy C22).

Drives

The SP-LR pumps are mounted with a close coupled stainless steel encased IEC B3/B5 foot/flanged motor and fitted with adjustable feet. The motor and impeller are coupled by a balanced stainless steel stub shaft. The motor can be supplied in all efficiency, isolation, protection and voltage classes. Also available in ATEX compliant version and in noise reduced execution. The SP-LR pumps can be supplied in a bearing house execution.



Shaft sealing systems

According to the hygienic standards of EHEDG the pumps can be supplied with several types of shaft sealing.

The standard shaft sealing is a single internal mechanical seal, however a single internal mechanical seal with quench is available as option.

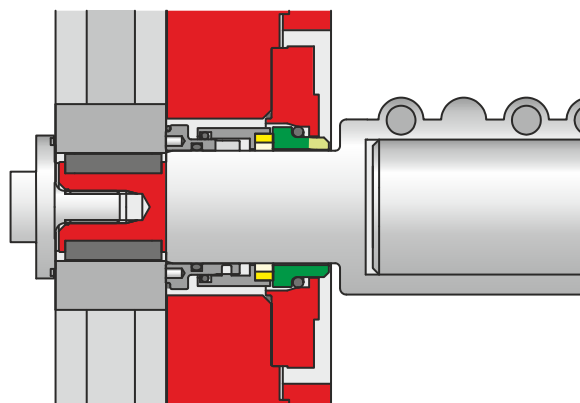

1. Internal mechanical seal

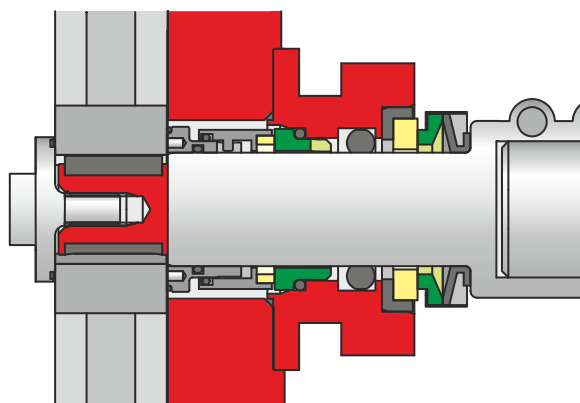

2. Internal mechanical seal with quench

The mechanical seals are available in the following materials combinations:

- carbon to CrMo-steel
- carbon to silicon carbide
- carbon to ceramic
- silicon carbide to silicon carbide
- tungsten carbide to tungsten carbide

The mechanical seals are available with EPDM, Viton, NBR and Teflon "O"-rings.

All materials comply with FDA - CFR 21 or the equivalent european standards.

Construction

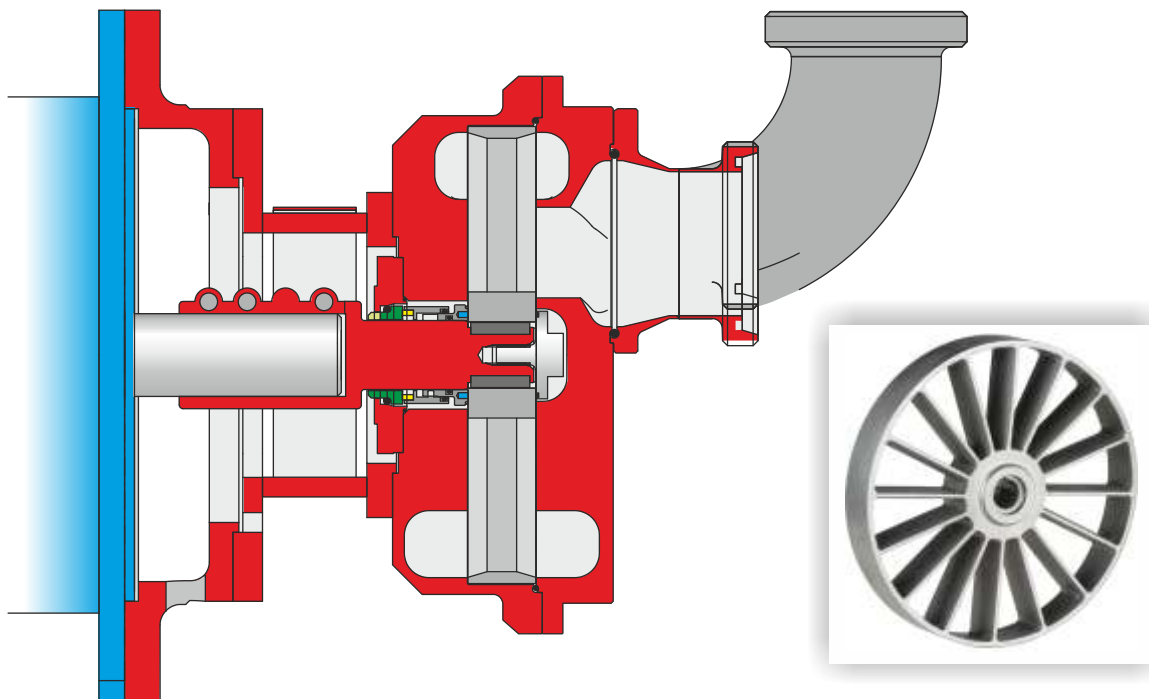

Dimensions

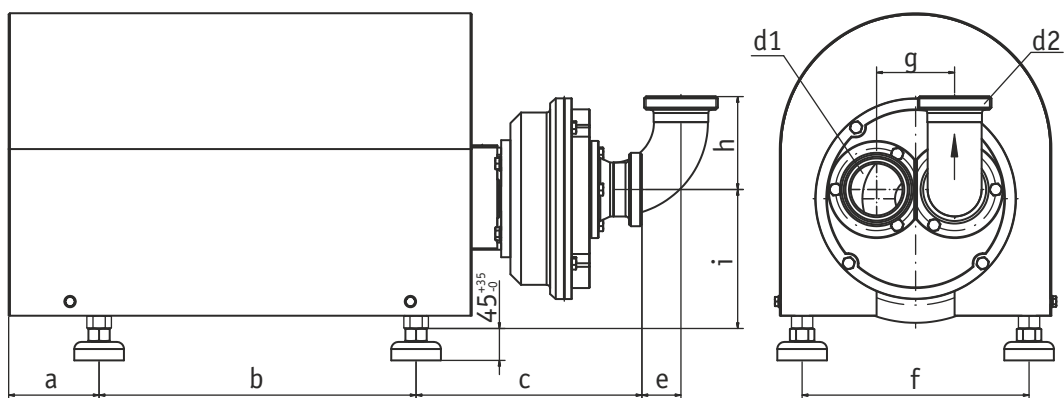

	c2	p3	P [kW]	a	b	c	e	f	g	h	i
SP-LR 186-1	2"	2"	2,2	32	390	234	32	200	80	102	134
SP-LR 186-1	2"	2"	3	32	390	234	32	200	80	102	134
SP-LR 186-2	2"	2"	3	32	390	234	32	200	80	102	146
SP-LR 186-2	2"	2"	4	32	390	234	32	200	80	102	146
SP-LR 186-2	2"	2"	5,5	32	452	234	32	250	80	102	166
SP-LR 232-1	2,5"	2,5"	7,5	32	452	241	42	250	94	131	168
SP-LR 232-2	2,5"	2,5"	7,5	32	452	241	42	250	94	131	168
SP-LR 232-2	2,5"	2,5"	11	128	447	318	42	320	94	131	196

Subject to alterations.

Curves

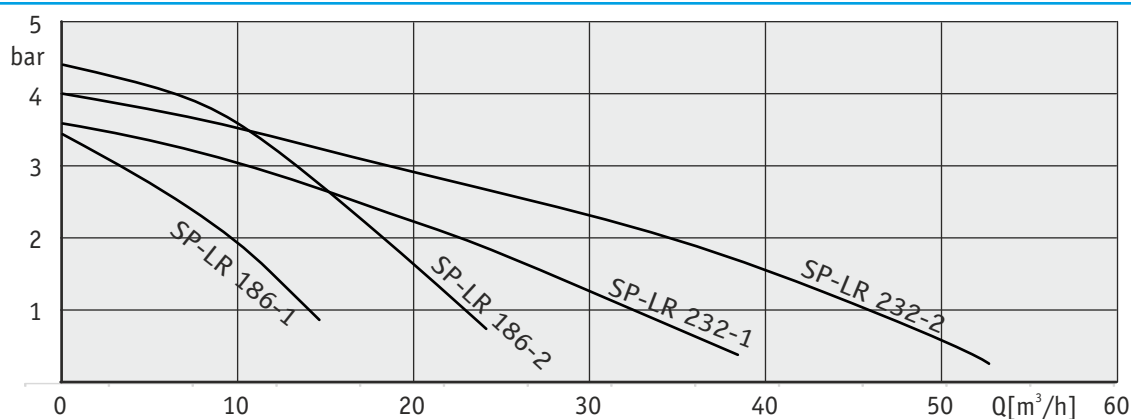

1500 min⁻¹

Besides the SP-LR-line pump assortment in this brochure the Pomac delivery program comprises an extensive choice of hygienic pumps.

More detailed information on these pump types is available and will be sent to you on request.

CPC
Stainless steel centrifugal pump

Q max = 600 m³/h
H max = 160 m



CPC-ZA
Self/priming stainless steel centrifugal pump

Q max = 200 m³/h
H max = 90 m



PLP
Lobe pump

Q max = 110 m³/h
P max = 25 bar



PDSP
Double screw pump

Q max = 90 m³/h
P max = 16 bar



CP-AGF
Pump with channel impeller

Q max = 1000 m³/h
H max = 25 m



Pomac Pumps

Pomac b.v
Feithspark 13 - 9356 BX Tolbert
P.O. Box 32 - 9356 ZG Tolbert
Holland
tel +31 (0)594 512877
fax +31 (0)594 517002
E-mail: info@pomacpumps.com
www.pomacpumps.com

Member of the Pomac Industries Group